



**Cooperative Research Centre for Coastal Zone, Estuary & Waterway Management**

Technical Report No. 14

# **Carbon and nutrient cycling in a subtropical estuary (the Fitzroy), Central Queensland**



**Final report  
Coastal CRC Project FH1**

**August 2005**

**G. Douglas, P. Ford, A. Moss, B. Noble,  
B. Packett, M. Palmer, A. Reville,  
B. Robson, P. Tillman and I. Webster**

# Carbon and Nutrient Cycling in a Subtropical Estuary (The Fitzroy), Central Queensland.

Final Report of COASTAL CRC  
Project FH1, (2000-2003)

Grant Douglas<sup>a,b</sup>, Phillip Ford<sup>a,b</sup>, Andrew Moss<sup>a,c</sup>,  
Bob Noble<sup>a,d</sup>, Bob Packett<sup>a,d</sup>, Mark Palmer<sup>e</sup>, Andy Reville<sup>a,f</sup>,  
Barbara Robson<sup>a,b</sup>, Pei Tillman<sup>a,b</sup> and Ian Webster<sup>a,b</sup>.

Addresses:

- a. Cooperative Research Centre for Coastal Zone, Estuary and Waterway Management
- b. CSIRO Land and Water
- c. Queensland EPA
- d. Queensland Department of Natural Resources and Mines
- e. CSIRO Mathematics and Information Sciences
- f. CSIRO Marine Research

**COASTAL CRC Technical Report Number 14**

## **Attribution of Authorship**

This project has been very much a multidisciplinary project and has required the input of the skills and energies of many people. Without all their efforts the project would not have been brought to fruition.

The Coastal CRC reporting format required that we identify the contributions of individuals and we set out the details below. For convenience we have broken the Project into major subject areas.

1. Regular estuarine sampling program for nutrients and physical parameter data. The sampling program was designed jointly by Phillip Ford and Andrew Moss and carried out by John Bennett and Phillip Thornton of the Queensland EPA and Bob Packett of the Coastal CRC. This data was then used in other elements of the Project as set out below. The tidal gauges were installed by Bob Packett, and the weather station was constructed and installed by Garry Miller and serviced by Bob Packett.

2. Sediment sourcing and geochemistry. Overall structure of this component was devised by Grant Douglas, the sample collection in the estuary was done by Phillip Ford and Bob Packett. Geochemical sampling in the catchment was designed by Grant Douglas and Phillip Ford, and carried out by Phillip Ford. The geochemical analyses were supervised by Grant Douglas and the data was analysed by Grant Douglas with statistical methodology devised by Mark Palmer. The paper describing this work was written primarily by Grant Douglas with inputs from Mark Palmer and Phillip Ford.

3. Conceptual model. The conceptual model (see Coastal CRC Technical Report Number 8. Conceptual models of the hydrodynamics, fine-sediment dynamics, biogeochemistry, and primary production in the Fitzroy estuary. Webster *et al.*, 2003) was developed under the auspices of Project CM2, but drew heavily on the knowledge and insights of the whole Project team working on the Fitzroy. Ian Webster was the principal author with inputs from Nugzar Margvelashvili on sediment dynamics, Barbara Robson on the biogeochemical aspects, John Parslow on the conceptual modelling, and advice from the rest of the modelling team.

4. Nutrient data analysis and budget construction. Pei Tillman assembled and quality controlled the nutrient and physical data and carried out the initial tidal analysis. Barbara Robson was responsible for the normalisation of the nutrient data to zero tide. The methodology for constructing the nutrient budgets was devised by Ian Webster including the development of the advection-diffusion approach. He was primarily responsible for the paper describing the method and the results.

5. Pesticides. The sediment pesticide subproject was designed by Bob Noble and Bob Packett. The chemical analyses were performed by Bruce Simpson, Phil Hargreaves and Mary Hodge. The approach of using crocodile eggs as a monitoring device was devised by Phillip Ford and Bob Packett, and the field collection program and liaison with crocodile egg suppliers was done by Bob Packett. The data analysis and paper preparation was done principally by Bob Packett.

#### 6. Sediment dynamics.

The experimental program was devised by Phillip Ford with advice from Nugzar Margvelashvili and carried out by Phillip Ford, Garry Miller, Bob Packett and Peter Voltz. The data analysis was carried out by Pei Tillman and she jointly prepared the written account with Phillip Ford.

#### 7. Carbon cycling and biomarkers.

The methodology for the estuarine investigations was devised by Andy Reville and he carried out the field collection of samples. The analytical work was done in his laboratory by Rebecca Esmay. Andy Reville was responsible for the data analysis and writing the account of the work. Sampling of catchment inputs was done by Bob Packett and Bob Noble, the samples were analysed for C and N isotopes by Richard Phillips (CSIRO Plant Industry) and the data analysed and the paper largely written by Phillip Ford.

### **Acknowledgements**

The above list sets out the formal responsibilities of project members for the preparation of this report, and the production of the reports and scientific papers which embody the knowledge and insights generated by the Project. There is, however, a large number of people who have contributed generously of their time, energy and knowledge. Without the help and guidance of our colleagues, officers in Queensland state agencies, members of community groups especially the Fitzroy basin Association (FBA), and the Rockhampton community we could not have achieved these results.

We express our gratitude to Pat and Adam Kelly for instrument deployments from the 'Southern Star', to Andy Davies who skippered our first cruise into the estuary, to Dave Ferris for diving and coxswain services and for being such a knowledgeable guide to the shoals, rocks and mudflats of the Fitzroy. Mark Percey helped in the sampling of the upper reaches of the Estuary. Peter Voltz (NRM) most helpfully provided data for inflows into the barrage and assisted in the field measurements of the sediment dynamics, and conducted the bathymetric survey which was invaluable for the nutrient budget calculations. Garry Miller provided electronics support and participated in the early field surveys. We thank the management for Pacific Salt for permission to install the weather station on their property at Port Alma.

<b>Index</b>	<b>page</b>
<b>EXECUTIVE SUMMARY .....</b>	<b>7</b>
<b>CHAPTER 1. PROJECT BACKGROUND AND MOTIVATION .....</b>	<b>10</b>
1.1 INTRODUCTION.....	10
1.2 MOTIVATIONS .....	10
1.3 CONCEPTUAL MODEL .....	12
1.4 OBJECTIVES.....	15
1.5 HISTORIC CONTEXT FOR THE PROJECT .....	16
<b>CHAPTER 2. LOADS AND INPUTS.....</b>	<b>18</b>
2.1 NUTRIENT INPUTS INTO THE UPPER ESTUARY .....	18
2.2 SUMMARY .....	20
<b>CHAPTER 3. PRIMARY PRODUCTION IN THE FITZROY .....</b>	<b>21</b>
3.1 INTRODUCTION.....	21
3.2 PELAGIC PRIMARY PRODUCTION.....	21
3.3 NATURE OF THE PELAGIC PHOTOSYNTHETIC ORGANISMS .....	22
3.4 MICROPHYTOBENTHIC PRIMARY PRODUCTION ON INTERTIDAL MUDFLATS .....	23
3.5 NATURE OF ORGANIC MATTER IN THE FITZROY ESTUARY .....	24
3.6 SAMPLING AND ANALYSIS .....	25
3.7 RESULTS AND DISCUSSION.....	26
3.7.1 <i>Characteristics of soils in the catchment and organic matter delivered to the estuary</i> .....	26
3.7.2 <i>Characteristics of the estuarine sediments</i> .....	26
3.8 CONCLUSIONS .....	35
<b>CHAPTER 4. BUDGETS FOR NUTRIENTS .....</b>	<b>36</b>
4.1 INTRODUCTION.....	36
4.2. THE INVERSE METHOD FOR ESTIMATING INFLOWS/OUTFLOWS .....	37
4.2.1 <i>Transport model description</i> .....	37
4.2.2 <i>Estimation of dispersion coefficient</i> .....	38
4.2.3 <i>Estimation of internal loading/losses</i> .....	39
4.3 NITROGEN .....	41
4.3.1 <i>Imports/Exports</i> .....	41
4.3.2 <i>Internal budgets</i> .....	43
4.4 PHOSPHORUS .....	45
4.4.1 <i>Imports/Exports</i> .....	45
4.4.2 <i>Internal budgets</i> .....	46
4.5 SILICA .....	48
4.5.1 <i>Imports/Exports</i> .....	48
4.6 CARBON DYNAMICS .....	49
4.6.1 <i>Introduction</i> .....	49
4.6.2 <i>Carbon imports from the catchment and exports from the estuary</i> .....	49

<b>CHAPTER 5. THE DELIVERY OF PESTICIDES TO THE FITZROY ESTUARY AND PERSISTENT ORGANIC POLLUTANTS IN THE FOOD CHAIN.....</b>	<b>51</b>
5.1 INTRODUCTION.....	51
5.2. PESTICIDES IN FLOODWATER FROM THE FITZROY CATCHMENT FOR THE YEARS 2002 AND 2003.....	51
5.3 PERSISTENT ORGANIC POLLUTANTS IN EGGS OF THE SALTWATER CROCODILE FROM THE FITZROY RIVER (A PRELIMINARY INVESTIGATION) .....	53
<b>CHAPTER 6. SOURCES OF SEDIMENT TO THE FITZROY ESTUARY .....</b>	<b>56</b>
6.1. INTRODUCTION.....	56
6.2. SAMPLING STRATEGIES, AND MAJOR AND TRACE ELEMENT ANALYSIS .....	57
6.2.1 <i>Estuary</i> .....	57
6.2.2 <i>Fitzroy catchment</i> .....	57
6.2.3 <i>Dams, weirs and flood samples</i> .....	57
6.3. RESULTS AND DISCUSSION.....	58
6.3.1 <i>Estuary sediments</i> .....	58
6.3.2 <i>Catchment soils</i> .....	58
<b>CHAPTER 7. SEDIMENT DELIVERY AND SEDIMENT DYNAMICS.....</b>	<b>63</b>
7.1 INTRODUCTION.....	63
7.2 FLOCCULATION AND AGGREGATION.....	63
7.3 SEDIMENT TRANSPORT DYNAMICS .....	65
7.3 EXPERIMENTAL OBSERVATIONS .....	66
<b>APPENDIX A. PUBLICATIONS ARISING FROM PROJECT FH1 .....</b>	<b>71</b>
<b>APPENDIX B. ABBREVIATIONS USED IN MAIN REPORT .....</b>	<b>72</b>

## EXECUTIVE SUMMARY

1. The Fitzroy River, which delivers nutrients, sediments, pesticides and freshwater into the Fitzroy estuary (the subject of the research reported here), is highly episodic with only a small number of brief (several days to several weeks) flood events each year.
2. The effect of these episodic events (provided the total flow is greater than 400-500,000 ML over several days) is to fill the estuary with freshwater and generate a surface plume of freshwater flowing across Keppel Bay.
3. Freshwater in the estuary after a flood event is gradually replaced by seawater, taking about 100 days to return the upper estuary near Rockhampton to near seawater concentrations.
4. For much of the year, the freshwater flows from the catchment are very small. Then inputs into the upper part of the estuary are limited to treated wastewater from the three waste water treatment plants in Rockhampton, flows through the fish ladder on the barrage, and limited releases from the two meat works near Rockhampton.
5. This project was conducted under drought conditions and thus the flows on which our observations are based were smaller than the median flow.
6. On an annual basis, inflow loads of both dissolved and particulate nutrients from the upland catchment are much larger than inputs from the other alternative sources – the wastewater treatment plants and urban stormwater discharge from Rockhampton. Sediments delivered to the estuary come almost exclusively from erosion of the upper catchment.
7. The deliveries of nutrients from Rockhampton are in the form of small continuous inputs principally of dissolved inorganic nutrients. In contrast, the episodic delivery of materials from the upper catchment is a mixture of dissolved and particulate nutrients.
8. The Fitzroy River is a macrotidal system (maximum tide 5+ m). The time of tidal maximum moving upstream increasingly lags the value at the mouth. The tidal flows are asymmetric with the inflow of shorter duration than the outflow. Consequently, inward tidal velocities are, on average, greater than outflow velocities, thus particulate material will be ‘pumped’ upstream.
9. Pelagic primary production is concentrated in the upper estuary and occurs once saltwater has penetrated upstream thus flocculating the fine particles causing them to settle and improving the light climate. The dominant pelagic photosynthetic organisms are diatoms and chlorophytes (small flagellates and coccoid forms).
10. Microphytobenthos (mpb) is an important component of primary production in the Fitzroy. It occurs on the intertidal mudflats throughout the estuary. Its abundance is highly variable spatially.

11. The suspended sediment from the upper catchment is the main source of particulate organic carbon and nitrogen to the estuary. This material is derived from soil and has a relatively low carbon and nitrogen content compared to temperate soils.
12. Mangroves and *in situ* primary production also deliver organic matter to the estuary but these are relatively small contributions.
13. The project has developed a mathematical transport model which accurately predicts salinity along the estuary after a flood.
14. Using the calibrated transport model and results of the monthly observations, we have constructed nutrient budgets for nitrogen, phosphorus, silica, and carbon for the estuary under high and low flow conditions. The results for nitrogen show:
  - Under high flows in summer 2000-1 Total Nitrogen (TN) inputs (2420 tonnes) equalled TN outputs to Keppel Bay.
  - River flows were much smaller the following summer (2001-2) and the TN input was smaller (600 tonnes) but only about half was transmitted to the Keppel Bay, with the remainder retained in the estuary.
  - Low-flow TN input was 95 tonnes and almost none was exported. The estuary thus acts as a sink. Import of particulate nitrogen through the mouth balanced the export of Dissolved Organic Nitrogen (DON) and Dissolved Inorganic Nitrogen (DIN) to Keppel Bay.
  - Under low flows the estuary received 83 tonnes (primarily DIN) and exported about the same amount.
15. The budget results for phosphorus derived from the transport model, and measured data show:
  - In the summer 2000-1 high flows the Total Phosphorus (TP) input was 980 tonnes and the output 760 tonnes.
  - In the smaller high flows of summer 2001-2 the TP input was 200 tonnes and the output 60 tonnes.
  - Under low flow conditions the TP input to the estuary was 11 tonnes and about nett 2 tonnes of TP was exported. However, Filterable Reactive Phosphorus (FRP) export to Keppel Bay was 20 tonnes so a balancing 22 tonnes of Particulate Phosphorus (PP) was delivered through the mouth into the estuary. This, and the TN balance(above) are consistent with the estuary acting as a sink for particulate materials
16. Under high flow conditions the delivery and export of dissolved silica (DSi) were in balance. Under low flow conditions the internal estuarine sources/sinks were too small to be detected suggesting that DSi produced by diagenesis in the sediments was taken up by mpb before it could enter the water column.
17. Under high flow conditions the import of DOC from the upper catchment is approximately balanced by the exports. More POC leaves the estuary than enters during a flood event indicating that resuspended sediments ‘pumped’ into the estuary from the mouth under low flows, are re-exported in high flows.



18. Despite intensive agriculture occupying only a small fraction of the Fitzroy catchment, floodwater samples showed detectable concentrations of the pre-emergence herbicides Atrazine and Diuron, and the woody weed herbicide Tebuthiuron. The concentrations exceeded ANZECC guidelines for 99% ecosystem protection.
19. A simple technique for investigating the presence of persistent organochlorine pollutants using infertile crocodile eggs was developed. A preliminary survey showed high concentrations (relative to pristine environments) of the degradation products of Dichloro-diphenyl-trichloroethane (DDT), indicating that these materials were still being delivered into the estuary and that they were being incorporated into the food chain.
20. A geochemical analysis of the sediments of the Fitzroy estuary, together with a representative sample of the catchment soils, and a more limited group of suspended solids retrieved during flood events and dam sediment samples showed that at the time of sampling, the estuarine sediments have a disproportionate amount of material derived from the Thompson Fold Belt geological provinces. The Bowen Basin geology is under-represented in the estuarine sediments.
21. The sediments delivered into the estuary are mainly finely divided clays with very long settling times in freshwater. Mixture with small amounts of saltwater (final concentrations ~ 1 ppt) results in rapid flocculation and rapid settling of sediments. Higher saltwater concentrations do not produce any additional effects.
22. Water column turbidity (and thus pelagic primary production) depends on the propagation of saltwater up the estuary after a flood, and the intensity of tidal resuspension of deposited sediments. Resuspension is the dominant process at the mouth and consequently, turbidity is high here with negligible pelagic primary production occurring. In contrast, resuspension in the upper estuary is greatly reduced after saltwater induced flocculation has occurred. Turbidity in the water column is then sufficiently reduced for substantial pelagic primary production. The turbidity increase down estuary is consistent with the numerical model developed in Coastal CRC Project CM2.
23. Measurement of suspended sediment profiles at different locations supports the hypothesis of upstream 'pumping' of fine sediments due to the tidal asymmetry. The estuary thus acts as a sink for sediments. Consequently, not all the sediment entering the estuary is irreversibly transported into Keppel Bay and beyond.

# CHAPTER 1. PROJECT BACKGROUND AND MOTIVATION

## 1.1 Introduction

In this chapter we:

- outline our perceptions of stakeholder issues;
- briefly describe a conceptual model of the biophysical functioning of the Fitzroy estuary;
- set out the objectives of the project; and
- describe the environmental conditions during the project against the historic behaviour of the Fitzroy River.

The first item reflects the motivations for the FH1 project – Carbon and Nutrient Cycling in Subtropical Estuaries. It sets out briefly the combined perceptions of the Coastal CRC's stakeholders and the project scientists, of those key issues where the biophysical sciences can contribute most effectively to a better understanding of anthropogenic impacts on the ecological processes occurring within the estuary. It is through the creation and adoption of this new knowledge that the community will be better able to make well-informed management decisions. The results will underpin a realistic evidence-based approach to land-use (broadly interpreted to include the estuary and waters within the coastal shelf) policy formulation.

Such policy considerations only make sense when viewed against a background of understanding how the estuary system functions. This knowledge is most easily accessible and understandable to both lay and scientific audiences when presented in the form of a conceptual model. Based on the early work of this project, a detailed conceptual model of the Fitzroy estuary was developed under the auspices of the Coastal CRC Fitzroy modelling project CM2 (Webster *et al.*, 2003). This conceptual model is a verbal description of the major environmental/ecological processes going on in the estuary system plus a schematic representation of such processes. The conceptual model is informed by our present knowledge of these processes derived from earlier investigations plus general scientific knowledge of the workings of analogous, and more intensively investigated, estuarine systems. We will not repeat the details here but offer a summary of the major points in Section 1.3.

In the third part of this chapter we provide a summary of our existing knowledge of the main processes high-lighted in the conceptual model. Readers more concerned with the results can skip this part of the chapter and proceed to the following chapters where the experimental results of this project are dealt with. Finally, we bring together the management and policy concerns, with the current understanding of how the system works biophysically to develop a research program which addresses the stakeholders concerns and defines the necessary scientific investigations which lead on to the scientific objectives of the project.

## 1.2 Motivations

The Fitzroy catchment is the largest Queensland catchment discharging to the Great Barrier Reef Lagoon. Although first settled about 150 years ago, the most profound

environmental changes have occurred over the past 40 years. The key elements of these changes are:

1. Very extensive land clearing leading to enhanced deliveries of sediments and land derived nutrients from the catchment. In the 19<sup>th</sup> century sheep were the major grazing animal but these were soon displaced by cattle which were managed under relatively low input/low intensity grazing regime. In the post-war era, the development of cattle breeds better adapted to the harsh conditions of the region, the adoption of improved pasture species, and the introduction of cheap land clearing techniques lead to a major 'burst' of land clearing in the catchment in the period 1960-1980 and this continues apace today. The consequences for the Fitzroy estuary were the delivery of elevated sediment concentrations relative to pre-European settlement (Brodie *et al.*, 2003; Furnas, 2003). When we started this project there was general concern about the possible impact of this material, including dissolved nutrients on the Great Barrier Reef. There was then, however, no formal government measures to limit these deliveries, or to rehabilitate the most degraded areas presumed to be the principal sources. In early 2003, the Great Barrier Reef Marine Park Authority identified the need to halve sediment deliveries from the Fitzroy. The Federal government also announced the National Action Plan for Salinity and Water Quality, with funding from the second round of the National Heritage Trust, to implement restoration works. Strategic decisions about assigning priorities for this work lie with the local/regional community groups. In the case of the Fitzroy this is the Fitzroy Basin Association.
2. The second major change of land use in the catchment was the development of irrigated agriculture. This started in the 1920's at Theodore in the Dawson subcatchment and initially involved row cropping. The scale of irrigated agriculture has increased markedly with the construction of numerous weirs through out the catchment (see Fig. 24 in Chapter 6) in addition to a major storage (Fairbairn Dam near Emerald). The focus of much of the irrigated agriculture has now switched to horticulture and cotton. Both forms of agriculture are characterised by more intensive management requiring the use of fertilizers and pesticides for weed and insect pest control. Dry land cereal production has also developed markedly following the realisation (Fitzpatrick and Nix, 1969) that such crops could be successfully grown using moisture stored in the soil. This requires leaving the ploughed soil bare for long periods awaiting rain, with the crop sown once sufficient water has been delivered to produce a crop. This practice has the potential to lead to greatly enhanced sediment, pesticide and nutrient deliveries from the catchment.
3. The Fitzroy catchment has very extensive surface water resources. Apart from Fairbairn Dam, all the storages are small relative to the size of the episodic discharges and most of the rainfall flows over the weirs through the estuary to the sea. The initial successes of irrigated agriculture noted above have prompted suggestions for the construction of large dams in the upper parts of the catchment. These dams, if built, have the potential to drastically impact on the ecology of streams due to changes in the quantity and timing of water delivered downstream of the storage, as well as having the potential to alter the character of the estuary. These issues were canvassed in the preparation of the

Fitzroy Water Allocation Management Plan which defined criteria for maintenance of ecologically desirable flows within the river. The Review Panel noted, however, that there was a paucity of information on which to base a confident judgment about the estuarine ecological response to markedly altered (largely reduced) deliveries of water.

4. The Bowen basin coal measures lie within the Fitzroy Basin. While the direct ecological consequences for the catchment appear to be small and commensurate with actual 'footprint' of the mine workings (< 1% of the total catchment), their development from the 1960s onwards has given a major economic impetus to the entire region. This has led to the expansion of Rockhampton as well as other towns in the region. Rockhampton and some of the rural towns discharge treated sewage into the Fitzroy and its tributaries and this material ultimately finds its way into the estuary. There are two major meatworks in the region which are licensed to discharge to the estuary also. The diminishing availability of land for large scale heavy industrial activity in Gladstone, together with the limits to water supply there, have led to Rockhampton, with its extensive areas of flat land and more assured water supply, becoming a focus for future heavy industrial/mineral processing activities. Thus the potential future discharges to the estuary of industrial effluents may be quite different in character from the present cocktail.

To summarise: the Fitzroy drains a large area of central Queensland. Many stakeholder concerns focus primarily on the ecological status of the estuary under present day conditions involving impacts of sediment, nutrients and pesticides from various agricultural activities in the catchment. The second major issue is the consequences for the estuary of significant reductions in the delivery of freshwater to the estuary. The third area of concern is the delivery of material via the estuary to the Great Barrier Reef. All these issues embody a close coupling between activities in the catchment and consequences in the estuary and coastal seas. This theme is explored in the exposition of the conceptual model given in the next section.

### **1.3 Conceptual model**

Our introductory remarks highlighted the function of conceptual models as aids to visualising our present understanding of how ecosystems work and documenting what the dominant processes are. The starting point of a conceptual model is our knowledge of the individual biophysical processes which go on within the system, and those forcing functions such as flow and mixing which determine the interactions between the various processes, as well as the changing spatial and temporal scales of these processes. As noted earlier, a detailed conceptual model was developed as part of Project CM2. We give here a brief summary of the major elements.

The light climate (amount of photosynthetically active radiation) within the estuary is an important factor as it determines the coupling between the nutrient supply and the primary production (fixation of carbon dioxide by photosynthetic organisms). As all the higher organisms such as crabs, prawns, fish, etc. derive their energy from this primary production, the factors controlling it determine the biological productivity of the estuary.

Primary production requires nutrients as well as light. In estuarine systems the nutrients which are in shortest supply, and thus limit the primary production are usually the inorganic forms of nitrogen, phosphorus, and sometimes silica – that is, biologically available forms of these elements which have not been incorporated into organic matter. These materials are delivered in the inflowing river and also regenerated within the sediments and water column by the bacterial breakdown of organic matter. This organic matter can be delivered with the riverine flow or produced *in situ* by photosynthesis. In the Fitzroy, the floodwaters usually have high concentrations of dissolved nutrients but, because of the turbidity of the water, the light climate is inadequate for growth of phytoplankton in the water column. Growth of microphytobenthic organisms (diatoms, cyanobacteria and some filamentous algae) can take place on the mud banks, but this is limited by the large tides preventing prolonged light exposure and resuspension.

In the Fitzroy, the floodwater entering the estuary is always very turbid due to the high concentration of suspended solids (the term sediments is used interchangeably in the text) though there are marginal differences in turbidity depending on the particular catchment the floodwaters come from. The catchment is dominated by clay soils and highly episodic river flows. Both observational data (discussed below) and modelling (Prosser, 2003) indicates that annual sediment delivery to the estuary is high and driven by episodic events. There are no significant sources of sediment (other than bank erosion) to the estuary downstream of the Barrage (including the City of Rockhampton). The vast majority of particles delivered to the estuary come from the upper catchment – the area well above the confluence of the Dawson and the Mackenzie Rivers. All of the major tributaries of the Fitzroy can serve as conduits for sediments. Experienced observers can make reliable guesses of the likely subcatchment which is the principal source of the water and associated sediments. Dawson water is characterised by a darker colour than water from the Connors/Isaacs streams and the particles are much slower to settle than those which are delivered by the Connors/Isaacs. Apart from the Fairbairn Dam on the Nogoia tributary above Emerald, none of the storage structures on the Fitzroy and its tributaries are sufficiently large, relative to flood flows, to act as effective sediment traps. Thus these structures retain very little of the incoming sediment sediments.

By definition, an estuary is a zone where freshwater from the land interacts with the sea. In the Fitzroy, the most obvious characteristic for the functioning of the estuary is the episodic delivery of water to the estuary. Flood flows are very intermittent. These flows usually occur in the monsoon season (December to March). They are produced by high intensity storms and lead to over-bank flows. Because of the nature of most of the soils in the catchment, such flows have high concentrations of very fine soil particles, and also transport pesticides and nutrients, both adsorbed to the particles and dissolved in the water. This highly turbid mixture is then delivered to the estuary by the flow. If the flow is sufficiently large the whole estuary is flushed with freshwater, and sediments and nutrients enter the coastal sea (Keppel Bay). The flow of the river is the dominant process in moving material into and through the estuary under flood conditions. For major flood flows tidal effects are minimal and the flow is uni-directional heading towards the sea.

In marked contrast, for the rest of the year, river flows are very small to negligible and the estuary is gradually flushed by the sea. The Fitzroy is a macrotidal system (has

large tidal range) and the tides move large amounts of water backwards and forwards in the estuary. The tidal motion gradually mixes the freshwater remaining from the previous flood with the seawater from the mouth of the estuary. Thus during these low flow periods the salinity, any point in the estuary, increases progressively towards that of seawater. The timing of this increase depends on location within the estuary. The wave of increasing salinity slowly advances from the mouth of the estuary to the Barrage at Rockhampton. The water column concentration and the spatial distribution of suspended sediments and dissolved nutrients during the low flow phase is determined by tidal effects. The net effect of the tidal exchanges is to move dissolved nutrients and freshwater from the estuary into Keppel Bay. In addition, during every tidal cycle, large quantities of particulate material are being resuspended, moved and deposited. The ultimate fate of these materials on the annual time scale of the estuary – whether they are deposited on the mud banks or flushed out to sea, depends on subtle differences between the in- and out-flows. Thus tidal asymmetries rather than flow velocities become more important in determining the final fate of materials delivered by the floods. The critical element for the conceptual model is that residence times for both dissolved materials in the estuary are now very long in contrast to the rapid one-way passage characteristic of the freshwater flows.

It is simpler to think of estuary existing in two different states each with its own conceptual model reflecting the profound differences between these states. Table 1 summarises the differences between the two states.

Table 1. Characteristics of the Fitzroy estuary and the major differences under conditions of high and low flows.

<b>Characteristics</b>	<b>Low flow case</b>	<b>High flow case</b>
Sediment concentration	Low and varying spatially with salinity along the estuary, and with the tide at any location	High and uniform throughout the estuary, but rapidly decreases within the flood plume as it moves off shore
Salinity	Increasing gradient from Rockhampton to the sea	Uniformly low
Nutrients (dissolved)	Spatially varying and, in general, lower than high flow case	Uniformly high throughout the estuary
Nutrients (adsorbed to particles)	Dependent on tidal re-suspension spatially non-uniform	High and uniform
Light climate and primary production	Varying with salinity and tide. Photosynthesis in the water column is only feasible well after passage of flood in the upper reaches of the estuary. Microphytobenthic production is feasible on exposed mudflats every tidal cycle	High turbidity prevents almost all photosynthesis in the water column through out the estuary

In developing the conceptual model it is also helpful to recognise the differences between the different parts of the estuary, and regard these areas as separate subsections within the conceptual model. These differences arise due to the shape of the estuary, the relative proximity to the mouth, and the timing of the penetration of saltwater following a flood. For instance, the ‘Town Reach’ near Rockhampton differs from other parts of the estuary in being much slower to clear after a flood, though the tidal velocity here, and thus resuspension, is much more limited than elsewhere in the

estuary. The clearing of the water column here occurs considerably after the sites further downstream due to the later penetration of the saltwater. The big loop in the estuary ('The Cut-through'), which was cut-off in the 1991 flood (see Fig. 5), is an area where tidal resuspension effects are diminished, especially at the distal end. Consequentially, it is a zone of rapid sediment deposition. In contrast, the mouth of the estuary is subject to the greatest tidal influences with the strongest currents and the maximum sediment resuspension. Thus we can break the estuary into a limited number of areas which have their own unique hydrodynamic characteristics (Table 2). This provides a further conceptualisation of how the estuary functions.

Table 2. Identification and characterisation of zones with different hydrodynamic or other properties.

<b>Zone of Fitzroy estuary</b>	<b>Tidal/current forcing</b>	<b>Salinity</b>	<b>Water clarity /turbidity</b>	<b>Primary production</b>
Mouth to Cut-through	Maximum	Predominantly saline ~ seawater	Always low	Water column – negligible; flow destroys microphytobenthos
Cut-through	Minimal at distal end. Zone of sediment deposition	Slower to flush with seawater but predominantly saline post-flood	Low immediately after a flood, but clears rapidly	Higher than surrounding areas
Upstream of the Cut-through to Devils Elbow	Decreased, though sufficient to cause resuspension	Flushes faster than the Cut-through	Low after a flood and remains low	Low and intermittent and best
Town Reach	Minimum	Predominantly freshwater except after a long time post-flood	Initially low but as salinity rises water clears	High and continuous after water clears

#### 1.4 Objectives

The objectives of this project emerge from bringing together the concerns and questions of the stakeholders regarding the possible changes in the ecological functioning of the Fitzroy estuary, with an understanding of the principal biological processes such as primary production which determines the amount and form of energy available to support the recreational and commercial fisheries. The principal physical factors such as turbidity, tidal flows, and salinity interact with the biological factors, so the capacity to predict how the Fitzroy estuary system will respond to changes of nutrients sediments, or volume of water, requires a knowledge of how these physical factors will vary as well. These considerations led to three principal objectives for this project:

- What are the present deliveries of sediments, nutrients and pesticides from the catchment, and what are there principal sources of these materials?;
- How are these substances transformed within the estuary, and how much, and in what form are they transmitted into Keppel Bay?; and

- How do the physical processes in the estuary interact with the biological processes along the length of the estuary, and over time since the previous flood?

Although not an explicit objective of this project, we recognised that much of the data we collected was important for the parameterisation and verification of mathematical models of the functioning of the Fitzroy estuary. Such models were seen as the best tool for delivering quantitative predictions about how the estuary would respond to changed inputs, and to explore the various scenarios of land use change in the catchment with a view to decreasing catchment impacts on the estuary. Accordingly, the research was shaped to gather information pertinent to the modelling effort, where possible, while pursuing our own main objectives.

The additional strong linkages between this Project and other Coastal CRC projects were with Project FH 5 – examining flow and commercial fisheries production relationships; and with RT 2 – investigating suspended sediment dynamics in estuarine systems. We have greatly benefited from the two-way exchange of information with these two projects and gratefully acknowledge this help.

### 1.5 Historic context for the project

As we noted earlier, flows of water from the catchment are highly episodic and vary considerably in size and duration from year to year. Figure 1 shows the yearly average discharges for the Fitzroy River since 1965. Note that the discharge is the discharge between July 1 in the previous year and June 30 in the nominated year. This ensures that the summer rainfall period falls within one averaging period. What is evident in the record is the enormous amount of interannual variability in the annual discharges. The year 1991 had an average discharge of  $730 \text{ m}^3\text{s}^{-1}$  whereas 1992 had an average discharge of only  $4 \text{ m}^3\text{s}^{-1}$ , more than two orders of magnitude smaller. The high average flows in 1991 were mostly due to a flood event with discharges of up to  $15,000 \text{ m}^3\text{s}^{-1}$  which lasted about two weeks. A second major flood occurred a month after this one.

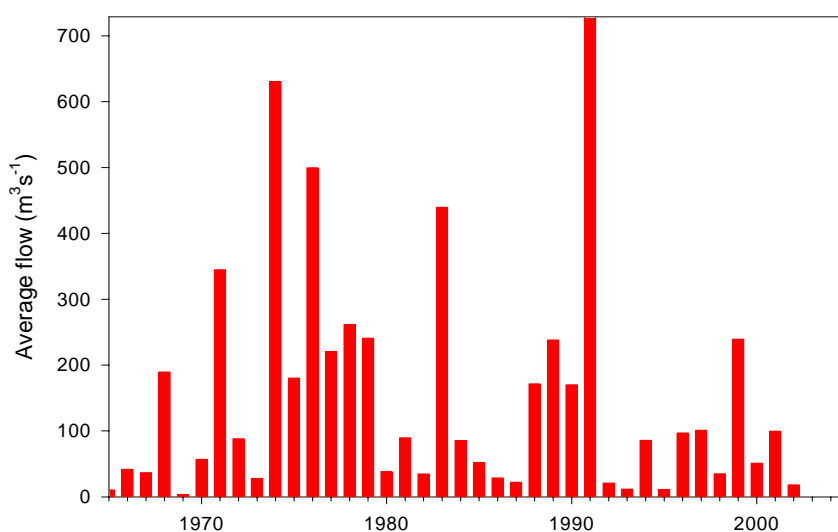
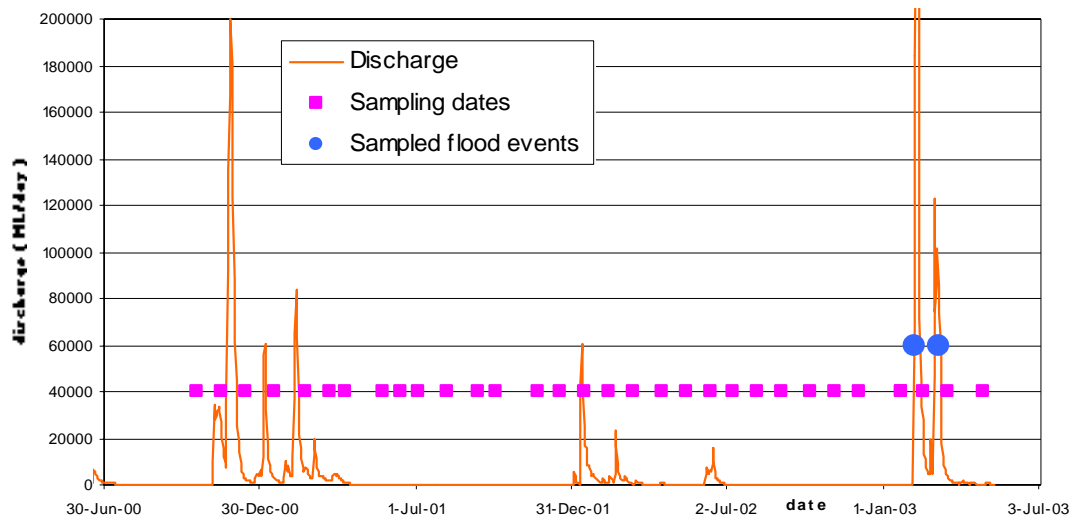

**Figure 1.** Average annual discharge from the Fitzroy River (measured at the Gap).



It is important to note that the Project ran from late 2000 to early 2003 and, as can be seen from Figure 1, the work was done over a time of well below average flows. The annual discharge for 2000/2001 was just above median and ranked 35 of 81. The two succeeding years were both below the median (2001/2002, 72 of 81; and 2002/2003, 46 of 81). The results report here, especially the budget calculations, remain valid despite these low flows. Readers, however, should keep in mind that the research has not sampled the full range of flow conditions which could be expected, on average, over a decade. The prolonged drought in the Fitzroy has continued until the time of writing (late 2004). While the Coastal CRC cannot mount a further investigation, we draw the attention of other agencies, both state and federal, to the importance of at least an *ad hoc* investigation during, and immediately after the next major flood. Coming after the drought it is likely to deliver well above proportionate sediment and nutrient loads. It will thus be an important upper bound on how the system behaves at present, as well as a good test of the reliability of our conclusions, and of models which aim to predict sediment and nutrient deliveries.

Not only are there major variations between annual loads delivered into the estuary by the Fitzroy, but there can be marked differences in how this annual discharge is delivered. In some flow years, such as 1993 and 1995, there was only a single flow event of short duration. In other years, such as 1999 and 2001, there was a sequence of flow events which spanned about 4 months. When a multiple flow events occur, the estuary is repeatedly flushed with freshwater as long as each individual event is larger than the estuary volume (about 400-500,000 ML). Each flushing effectively ‘restarts the clock’ for the transition to the low flow state when the freshwater is gradually displaced by saltwater slowly mixing up the estuary. Under these multiple discharge events the upper part of the estuary remains fresh much longer than is the case if there had been a single (larger) discharge of the same volume. Figure 2 shows the daily discharge pattern during the Project, together with the dates (indicated by the red squares) when nutrient samples were collected along the estuary as part of our systematic monitoring program, together with the two closely spaced events (indicated by the blue dots) which we sampled for pesticides. Only two of the events were large enough to completely flush the estuary while the others caused only limited displacement of saltwater.



**Figure 2.** Daily discharge of the Fitzroy River at the Barrage, and routine along-estuary sampling dates during Project FH1.

## CHAPTER 2. LOADS AND INPUTS

### 2.1 Nutrient inputs into the upper estuary

There are four potential sources delivering dissolved and particulate nutrients into the upper Fitzroy estuary. They are:

1. from upstream during flood events, and by releases through the barrage and associated fish ladder under low flow conditions: Using measured discharges (at the Gap) and nutrient concentrations at the barrage from samples collected during floods, or by extrapolation of concentration vs. salinity plots, we have calculated annual loads during recent floods. This material is generally delivered at the head of the estuary, but under flood conditions some of the waters leave the main stem of the river above Rockhampton and re-enter the estuary well below Rockhampton. Because of rarity of flood events we have supplemented these 'end-of-system' loads with loads calculated for intermediate points in the major rivers which combine to form the Fitzroy. There is good data covering both discharge and nutrient concentrations for events in these systems. Our work using natural radionuclides show that the Fitzroy system is quiet efficient in transmitting material. Thus, these loads are lower bounds (i.e. underestimates) of the quantities of material delivered to the estuary;
2. materials delivered by stormwater discharges from the Rockhampton urban catchment into the upper estuary: We have estimated these inputs using coefficients for urban runoff collected in South East Queensland (estimation of pollutant concentrations for EMSS modelling of the south east Queensland region by F.H.G. Chiew and P. Scanlon). There are major uncertainties in these calculations arising from the runoff coefficient (fraction of the amount of rainfall that actually reaches the stream), as well as lower and upper estimates of the concentrations of nutrients. There are different concentrations for urban and rural subcatchments. We have assumed that stormwater is generated from an urban area of 30 km<sup>2</sup> and a rural area of 100 km<sup>2</sup>. This material is delivered via a number of creeks (Moore's, Frenchman's, Thozet's Creeks and Lakes Creek) which enter along the length of the upper estuary. All enter the estuary above our most seaward station and so their effects, if significant, should be apparent in the salinity and concentration effects at the downstream sites;
3. discharges from the three waste water treatment plants operated by Fitzroy River Water which deliver treated effluent at three points along the 'Town Reach' of the estuary: Annual loads have been calculated based on measured concentrations and daily discharges reported under Fitzroy River Water's licence conditions. As part of this project supplementary measurements were made of dissolved nutrient concentrations; and
4. dissolved nutrients are moved down stream and diluted by the seawater which gradually displaces the freshwater under low flow conditions: We have used a nutrient budgeting method to quantify the nutrient budget for the upper reach of the estuary under

Tables 3 to 7 below show the results of the combination of calculation, modelling and observations.

Table 3. Calculated annual loads of TN and TP delivered over the barrage into the upper estuary.

<b>Year</b>	<b>Total Phosphorus (tonnes)</b>	<b>Total Nitrogen (tonnes)</b>
1994	1362	5835
1995	117	5834
1996	1454	6240
1997	844	3055
1998	1838	5744

Table 4. Estimated loads (tonnes) for single events, measured at specific locations within the Fitzroy catchment. These quantities are lower estimates of the material which would be delivered to the upper estuary by each event.

<b>Location (date)</b>	<b>Ammonium</b>	<b>Oxidised Nitrogen</b>	<b>Filterable Reactive Phosphorus</b>	<b>Total Phosphorus</b>
The Gap (Feb 1995)	1.96	167.9	10.76	141.8
Woodleigh (Nov. 1995)	3.76	38.9	7.34	75.4
Woodleigh (Mar. 1998)	5.14	104	32.6	127.79
Theodore (Jan-Feb 1996)	110	161.7	83.5	377

Table 5. Estimated annual loads of TN and TP delivered by stormwater from immediate Rockhampton urban and rural catchment to the upper estuary of the Fitzroy.

<b>Estimate</b>	<b>Total Suspended Solids (tonnes)</b>	<b>Total Phosphorus (tonnes)</b>	<b>Total Nitrogen (tonnes)</b>
Low	2000	8.6	67
High	20400	41.6	338

Table 6. Annual loads delivered to the upper Fitzroy estuary by discharges from the Fitzroy River Water wastewater treatment plants.

<b>Waste Water Treatment Plant</b>	<b>Total Phosphorus (tonnes)</b>	<b>Total Nitrogen (tonnes)</b>
North	12.26	23.67
South	13.2	38.6
West	3.89	13.1
<b>Total Input</b>	<b>29.35</b>	<b>75.37</b>

Table 7. Daily Nutrient budgets for the upper estuary (0 to 8 km) derived from modelling of nutrient concentrations (See Chapter 4).

<b>Flow state</b>	<b>Import</b>	<b>Export</b>
High flow	TN: 52.7 TP: 23.3	TN: 50.8 TP: 18.2
Low Flow	TN: N/A TP: N/A	TN: 0.4 TP: 0.05

## 2.2 Summary

1. Comparison of the four potential sources of nutrients to the upper estuary clearly show that the high flow loads on an annual, or even event, basis are much greater than any of the other nutrient sources. Most of this material is transmitted through the estuary but a small proportion appears to be retained (Table 7).
2. The annual nutrient contribution of stormwater is approximately the same size (based on the lower estimates) or larger (using the upper estimates) as the inputs from the three waste water treatment plants. If this local rainfall is simultaneous with generalised rainfall in the Fitzroy catchment, then the stormwater-delivered material will be quickly flushed to the sea by the flood flows. If the stormwater-generated flows arise from purely local rainfall, then the nutrient concentrations in the estuary are likely to be at least comparable with those resulting from flood flows and will be retained in the upper estuary until mixed out by tidal exchange and the gradual advance of saltwater up the estuary. First order estimates of the time required to reduce the initial concentration by 50% vary from 45 days (Station 1; 2 km from the barrage) to 23 days (Station 6; 14 km from the barrage at the Nerimbera boat ramp).
3. Annual inputs from the three wastewater treatment plants are comparable to the calculated stormwater loads. The wastewater inputs are, however, spread over a year and the rate of nutrient input is considerably less. The results of the budget analysis suggest that at least comparable amounts of nutrients are exported down stream on a daily basis from the upper estuary, as enter from the treatment plants. Examination of the upper estuarine nutrient concentration time series for low flows show a monotonic decrease in some nutrient concentrations (i.e. TP), while others such as oxides of nitrogen ( $\text{NO}_x$ ) show an apparent random variation about a mean value. Overall the results show that there is no build-up of nutrients in the upper estuary during the low flow period when the Waste Water Treatment Plant inputs are the sole anthropogenic source.
4. It appears that the tidally driven exchange and biological uptake by primarily benthic organisms, as well as sediment denitrification are sufficient to balance the human inputs plus the nutrient inputs arising from sediment diagenesis of nutrient containing materials deposited during the floods.
5. Primary production in the water column (pelagic production) is light-, rather than nutrient-, limited. The observations of the spatial distribution of high concentrations of chlorophyll in the water column seen in the later sampling cruises is consistent with this view. The location of the areas of lowest turbidity in the upper estuary are determined by the interplay between the characteristics of the incoming water from either flood or stormwater inputs, and the extent of penetration of saltwater.

## CHAPTER 3. PRIMARY PRODUCTION IN THE FITZROY

### 3.1 Introduction

Primary production is the conversion by living photosynthetic organisms of carbon dioxide from the air or water, plus inorganic nutrients into organic matter. This process, which is undertaken by a wide range of organisms, is the key linkage between the inputs of nutrients into the Fitzroy estuary, and its ecological functioning. The physical processes such as turbidity of the incoming water and sediment resuspension which control the light climate in the estuary, and tidal mixing which determines the residence time of nutrients in the estuary act to limit the overall primary production. As we noted in our earlier discussion of nutrient budgets (Chapter 2) the availability of light, rather than the availability of nutrients, is the principal factor limiting primary production. The fixed organic carbon produced is the principal energy source for the estuarine ecosystem especially the higher trophic levels such as fish and crabs. Floodwaters deliver additional organic carbon both in the dissolved and particulate forms. However, some of this material is 'relic' particulate material which is not easily metabolised, and the dissolved fraction is taken up by bacteria in the water column and sediments. Mangroves are also contributors of organic carbon to the estuary through fallen leaves and the filamentous algae which grows on their roots, though this investigation did not examine mangrove production. The amount, and form, of the organic carbon produced in the system determines the overall biological productivity of the system. Our efforts have concentrated on characterizing primary production in the water column (pelagic), and by the microphytobenthos (mpb – a mixture of diatoms and cyanobacteria) which live on/in the intertidal mudflats.

### 3.2 Pelagic primary production

The abundance of chlorophyll *a* in the water column was used as a measure of primary production by phytoplankton. Chlorophyll *a* was measured approximately monthly at each of the 12 standard sampling stations along the estuary for two years. The combined results are brought together in Figure 3. The results show that while high concentrations of chlorophyll are reached, these instances are intermittent and occur predominantly in the higher reaches of the estuary generally upstream of the Cut-through. The most persistent blooms with the highest chlorophyll concentrations are usually located in the top 10 km of the estuary. This stretch of the estuary corresponds to the 'Town Reach' and the blooms here are the cause of odour problems noted by Rockhampton residents. Outside of this area there was only one bloom in the Cut-through (in October 2000), and a minor bloom upstream of Nerimbera in June 2002. Examination of local rainfall records suggests that nutrients were flushed into the estuary by stormwater discharges. The volume of water was not sufficient to drastically reduce the salinity (see later) so the particles in the stormwater were rapidly flocculated leaving a nutrient-rich, but relatively clear, water column where rapid phytoplankton growth could occur.

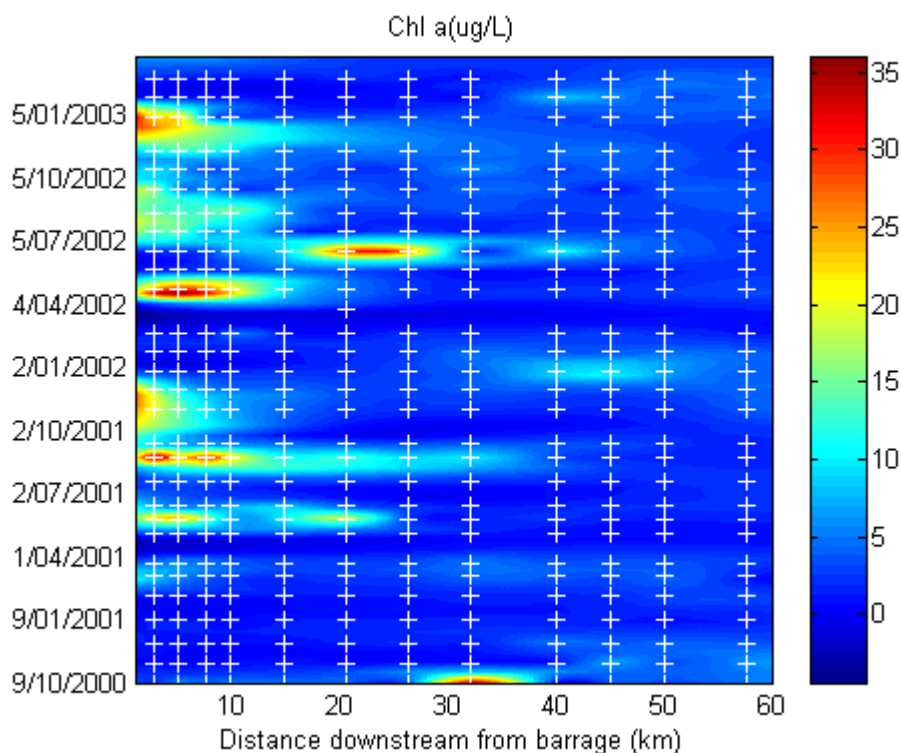

**Figure 3.** Chlorophyll *a* concentration (measured in  $\mu\text{g/L}$ ; see right-hand vertical scale) in the estuary water column at all sampling stations October 2000 to April 2003.

### 3.3 Nature of the pelagic photosynthetic organisms

Water samples were collected at four sites in the upper estuary in September 2001, preserved in Lugol's solution and after concentration were counted by an expert Phytoplankton taxonomist (Dr Julie Phillips, University of Queensland). The results (Table 8) show reasonable uniformity between all the sites which were dominated by mixtures of Bacillariophytes (Diatoms) and Chlorophytes (which were mainly small flagellates and coccoid forms) with the green flagellate *Chlamydomonas ehrenbergii* common at all sites.

Table 8. Abundance (cells  $\text{ml}^{-1}$ ) of pelagic phytoplankton at four sites in the upper Fitzroy estuary, September 2001.

Algal Division	Site 1	Site 2	Site 3	Site 4
Bacillariophyta	29.6	25.1	26.0	58.4
Chlorophyta	47.6	55.7	20.6	101.5
Cryptophyta	14.4	12.6	11.7	38.6
Cyanobacteria	6.2	10.8	0	0
Dinophyta	0	0	0	7.2
Euglenophyta	2.7	1.8	1.8	0
<b>Total</b>	100.5	109.6	60.1	205.7

At sites 1 and 2, *Chaetoceras* sp. were the dominant diatoms with only a few *Skeletonema costatum*, whereas at sites 3 and 4, *Skeletonema costatum* was the dominant diatom. The settling velocity of both *S. costatum* and *Chaetoceras* is approximately  $0.7 \text{ m d}^{-1}$ . Thus in this part of the estuary which is between 5 m and 10 m deep the diurnal tidal motion is sufficient to resuspend most sinking phytoplankton

before they reach the bottom and return them to the better illuminated parts of the water column (i.e. surface waters).

### **3.4 Microphytobenthic primary production on intertidal mudflats**

Because of the large tidal range throughout the Fitzroy estuary reasonably large areas of mud flat surfaces are exposed at low tide and provide suitable sites for growth of microphytobenthos (mpb). These areas are readily recognised by the khaki-green surface layer. The close coupling between this form of primary production and higher trophic levels is seen in Figure 4. Here, the scrapes where the organic-rich layer has been removed are clearly visible around the small crab burrows.

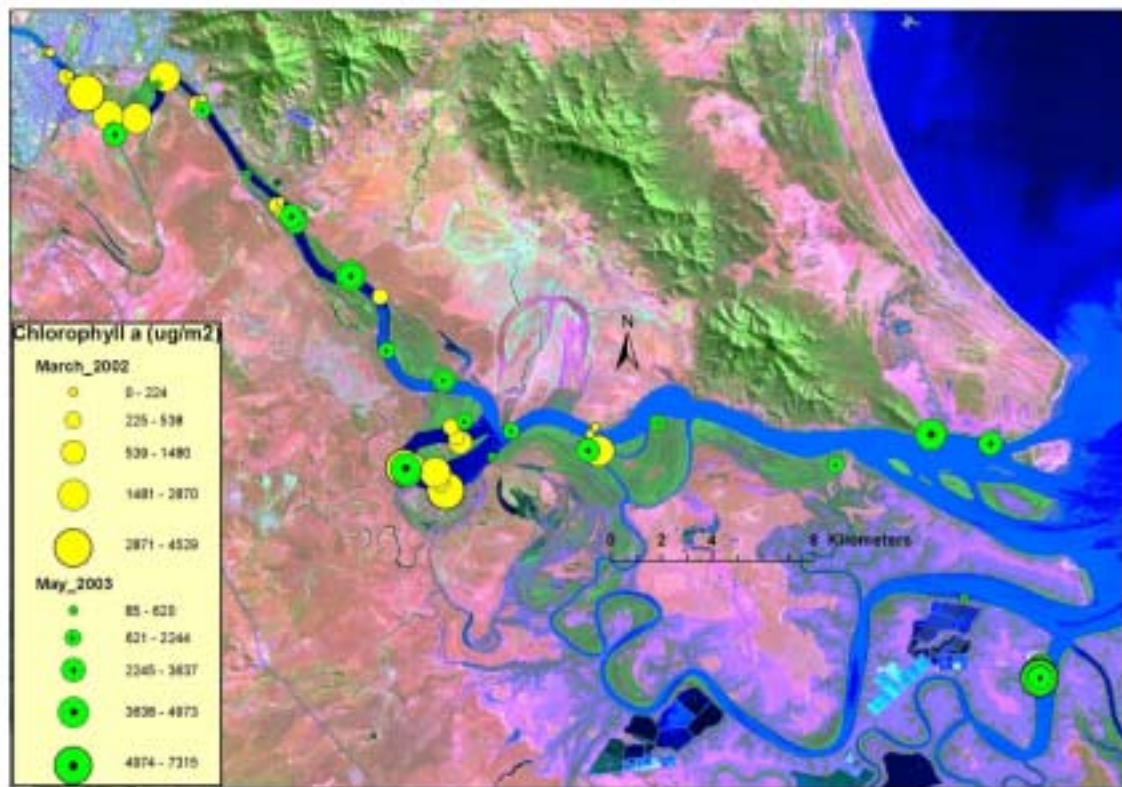

**Figure 4.** Intertidal area on Pongy Creek showing layer of microphytobenthos (mpb) and scrapes (centre) where the mpb has been removed by small crabs as food (Photo: Ian Halliday).

The abundance and spatial distribution of mpb within the Fitzroy estuary was investigated on two occasions: in March 2002 and March 2003. The first cruise was about three months after a very small flood event, while the second cruise was approximately three months after a much larger event (though still small in the overall context of inflows into the Fitzroy). The abundance of mpb was quantified by measuring the chlorophyll content of surface (0 to 5 mm) sediment samples collected from the intertidal area. The results (Fig. 5) show that there is a wide variation (about two orders of magnitude) in concentration between the various sites, and there is no apparent systematic trends in the spatial distribution of mpb. Areas of high and low sediment chlorophyll concentration lie in close juxtaposition. There seems to be little inter-annual variation. It seems likely that local factors are the principal determinants of the abundance of mpb. These factors include the existence of a suitable substrate – a mudflat undergoing deposition rather than erosion, and good exposure to the sun. Under high tidal flows it is possible that some of the surface layer may be resuspended, and the resuspended mpb are then distributed uniformly through the water column and sink out. This provides a mechanism for the transport of fixed organic carbon from the productive edges to the light limited, and unproductive,



deeper waters. We noted, on occasion that prawn trawling in some intertidal areas had completely removed the surface mpb. It is possible that this removal of a significant food source for prawns will have a deleterious effect on the total prawn catch. Mpb primary production contrasts strongly with the pelagic primary production. Pelagic production is spatially and temporally constrained. It can only occur in the upper estuary and in the distal parts of the Cut-through after the salinity has increased with the influx of seawater post flood and the light climate has improved. Tidal resuspension in the lower estuary always ensures that the light climate there is unfavourable to pelagic primary production. In contrast, mpb is neither spatially nor light constrained and is able to grow throughout the estuary where ever there is a suitable substrate.



**Figure 5.** Chlorophyll concentration ( $\mu\text{g}/\text{m}^2$ ) (phaeophytin corrected) in surface sediments (0 to 5 mm) in the Fitzroy estuary March 2002 and March 2003.

We can make an assessment of the relative amounts of pelagic and mpb biomass by considering the resuspension of all the mpb into the water column. If we take the average depth of the water column to be 5 m and assume that the mudflats make up 20% of the total area (a generous assumption), then a surface sediment chlorophyll concentration of  $5000 \mu\text{g L}^{-1}$  (the maximum found) will correspond to merely  $0.2 \mu\text{g L}^{-1}$  which is much lower than the measured pelagic chlorophyll concentrations.

### 3.5 Nature of organic matter in the Fitzroy estuary

In the earlier parts of this chapter we discussed the evidence for primary production within the Fitzroy estuary by organisms living in the water column (pelagic primary production) and the contribution of the complex of cyanobacteria and diatoms living in the intertidal mudflats (mpb). There are other potential contributors of metabolisable organic matter to the estuary. These other sources include organic



matter from agricultural land in the upper catchment as well as floodplains and wetlands. Organic matter from all these sources is delivered to the estuary during flood events. Mangroves growing along the banks of the estuary and bacteria within the water column and sediments are more immediate and a constant source of organic carbon to the estuary.

To ascertain the relative contribution of these other sources of organic matter we have used a combination of the measurement of the carbon and nitrogen content, as well as the stable isotope ratios of these elements in the sediment material, together with an investigation of the lipid biomarkers. These isotopic methods rely on the 'signature' that the producing organism imposes on the carbon and nitrogen ratio, and the relative amounts of the stable isotopes of carbon ( $^{13}\text{C}/^{12}\text{C}$ ) and nitrogen ( $^{15}\text{N}/^{14}\text{N}$ ) in the organic matter they produce. For instance freshwater phytoplankton have a atomic C:N of about 8, whereas the  $^{13}\text{C}/^{12}\text{C}$  (expressed in standard form relative to the international standard) is -26 to -30‰. Many of the organic compounds synthesized by living organisms have distinctive chemical structures which can be used as a 'biomarker' for assigning sources to particular groups of organisms (e.g. terrestrial plants, bacteria, microalgae). In some cases the presence of a particular biomarker can be used to distinguish specific subgroups of organisms within these general classifications (e.g. mangroves, sulphate-reducing bacteria, diatoms and dinoflagellates).

As it is rare for a single living organism to totally dominate a particular aquatic environment, the sediments always contain a mixture of biomarkers characteristic of the whole spectrum of producer organisms. Using well established techniques it is possible to separate the various biomarkers into particular chemical classes such as sterols, alcohols, fatty acids and neutral compounds. The individual compounds within each class can then be separated by gas chromatography and identified conclusively by their gas chromatographic retention times, comparison with authentic reference compounds, and mass spectroscopy.

### **3.6 Sampling and analysis**

Thirty-six soil samples were taken from a random selection of >100 soil samples collected through out the Fitzroy catchment as part of the sediment sourcing investigations (See Chapter 6) and the finest fraction (<10  $\mu\text{m}$ ) were isolated by settling. Samples of the sediment entering the estuary from the catchment were collected at the Fitzroy Motor Boat Club (2 km downstream from the barrage) during flood events in February and March 1998, and January 2002. The carbon and nitrogen contents, together with the stable isotopic ratios of C and N were measured (after removal of carbonate) on both the soil samples and the suspended material entering the estuary.

Estuarine sediment samples were collected in December 2001 at all the stations used for the geochemical sampling (see Chapter 6). Locations are shown in Figure 6. Subsequently, samples were collected from a subset of the same sites (determined by logistics and weather conditions) in March 2002, December 2002, and March 2003. Carbon and nitrogen content, stable isotopic ratios and, lipid biomarkers were measured on the estuarine sediments.

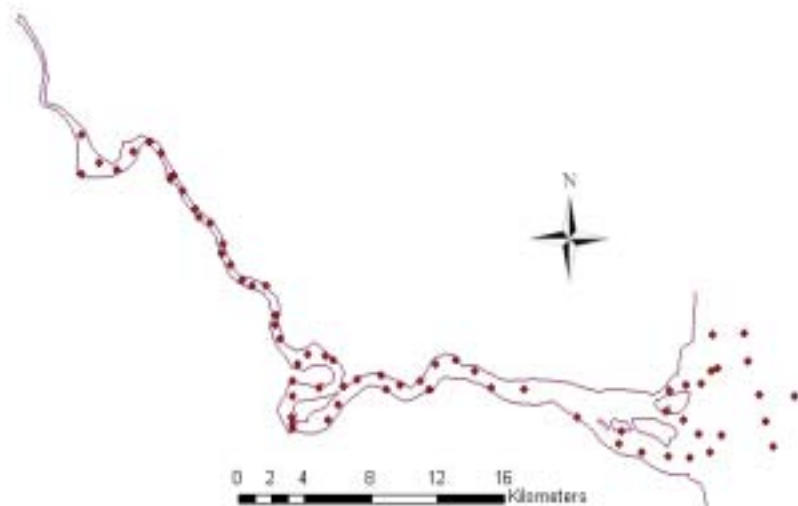

**Figure 6.** Location of organic carbon and biomarker sampling sites in Fitzroy estuary.

### 3.7 Results and discussion

#### 3.7.1 Characteristics of soils in the catchment and organic matter delivered to the estuary

The catchment soils have an average C:N ratio of 14.8, a  $\delta^{13}\text{C}$  of  $-22.5\text{‰}$  (standard deviation (SD) = 1.1), and a organic carbon content of 1.6% (SD = 0.4). These values are characteristic of the soil organic matter-primarily weathered plant remains absorbed to clay particle surfaces (Ford *et al.*, 2005). Apart from a more negative signal ( $\delta^{13}\text{C} = -27\text{‰}$ ) at low Total Suspended Sediment (TSS) concentrations ( $< 200 \text{ mg L}^{-1}$ ) at the start of the 2002 floods indicative of freshwater algae flushed from upstream during the early stages of the rising flood, the average  $\delta^{13}\text{C}$  of the suspended sediment entering the estuary was  $-21.3\text{‰}$  (SD = 1.3) and its organic carbon content 1.5% (SD = 0.2). The strong agreement between the various parameters is good evidence (supported by investigations of the natural radionuclides delivered during flood events) that the bulk of the particulate organic carbon delivered to the estuary is soil organic matter, and that it undergoes only slight changes, at most, in transit from the catchment to the estuary.

#### 3.7.2 Characteristics of the estuarine sediments

Figures 7 and 8 show carbon and nitrogen content of the sediments for four 4 surveys. The range of concentrations for carbon was 0-1.6% (dry weight) and 0-0.2% for nitrogen. These values are quite low compared to temperate estuarine systems, where carbon values can often be up to 5%. However, they are similar to those found in other tropical estuaries such as the Ord River. The low carbon and nitrogen content are consistent with C and N 'poor' sediments being transported from the catchment. To assess the significance of other potential contributing factors, such as minor *in-situ* primary productivity, or limited transport from adjacent mudflats the source of the organic matter needs to be determined.

One preliminary indication of organic matter source is the ratio of carbon to nitrogen (C:N). Marine (algal derived) organic matter tends to have a C:N of 8 or less, while terrestrially derived organic matter is  $> 8$ , usually of the order of 10 or more. Figure 9

shows plots of the relationship between %C and %N for samples collected on each survey and also shows the C:N = 8 line. In each case, except March 2002, %C and %N show a close correlation, indicating that the two are coupled. In December 2001 there was a tight correlation, with all samples plotting below the 8:1 line, indicating a predominantly terrestrial origin for the organic matter. In contrast, in March 2003 there was again a tight correlation between the two, but samples with a higher carbon content plot above the 8:1 line, indicating a lower C:N value and a shift from terrestrially derived organic matter to a marine source. This may indicate increased *in-situ* production or material from Keppel Bay being 'imported' into the estuary. This is slightly unusual in that a generalisation for estuaries would be that higher carbon contents tend to be associated with terrestrial material, thus we would expect samples with the highest %C to plot below the 8:1 line (high C:N).

Figures 10 and 11 show the results for the analysis of stable isotopes of carbon and nitrogen, respectively. It is important to note that due to the low levels present, especially of nitrogen, these figures need to be treated with some caution.  $\delta^{13}\text{C}$  values in estuaries tend to range from -29‰ to -25‰ for terrestrially derived plant or algal material, with soil organic carbon around -22‰, to -18 to -16‰ for marine inputs. In the Fitzroy estuary, average values tend to be around -24‰ which can be indicative of a mixture of terrestrial and marine inputs. Another explanation for similar values could be due to the nature of the terrestrial inputs, for example grasslands can have a carbon isotopic signature of around -24‰ (or even more enriched if they contain the so-called 'C4 plants' which use a particular biochemical pathway to fix  $\text{CO}_2$  leading to relatively 'light'  $\delta^{13}\text{C}$  values i.e. less negative. This latter explanation might well be the more likely when considering that in general the organic matter had C:N values of  $> 8$  (Fig. 9). However, it is possible to see the increase in marine derived carbon during March 2003 (Fig. 9) which is in agreement with the shift to lower C:N values during the same period, indicating that the organic carbon contribution is due to primary production in the estuary.

In general, nitrogen isotope values in estuaries tend to range from 0‰ (terrestrial N fixation) to +8‰ (marine inputs). In the Fitzroy, values appear to be highly variable but it is important to remember that nitrogen content in the sediments was very low and this can significantly influence the accuracy and reproducibility of stable isotope results. However, it would appear that most of the sedimentary nitrogen in the Fitzroy originates from sources with values around +5‰ or greater. This could be due to a mixture of terrestrial and marine nitrogen or it could be due to other anthropogenic inputs (however these have not been investigated). It is noteworthy, however, that the highest  $\delta^{15}\text{N}$  values are always in the upper part of the estuary, where the uptake of sewage derived N with a large positive signature (8-16‰) would be most abundant. Because of the high turbidity due to tidal action in the mouth of the estuary, primary production in the water column would be greatest in the upper estuary and therefore so would be the uptake of inorganic nitrogen.

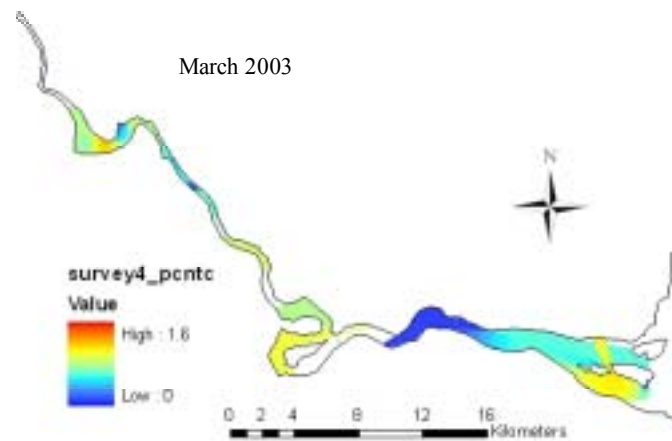
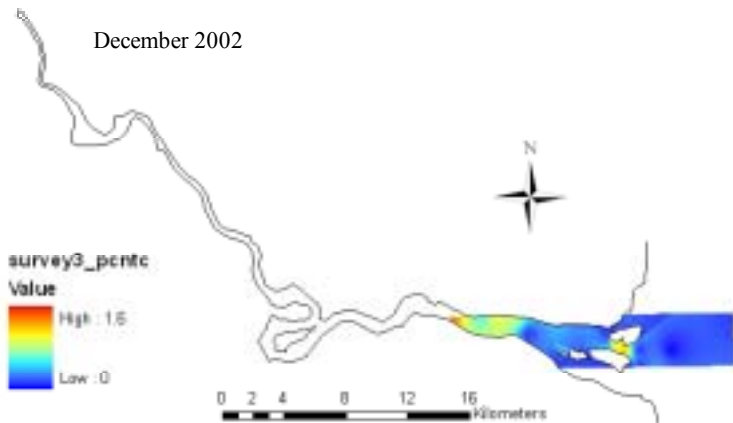
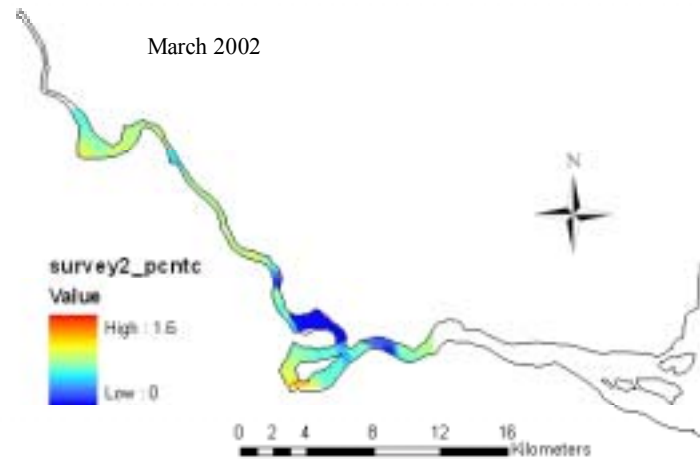
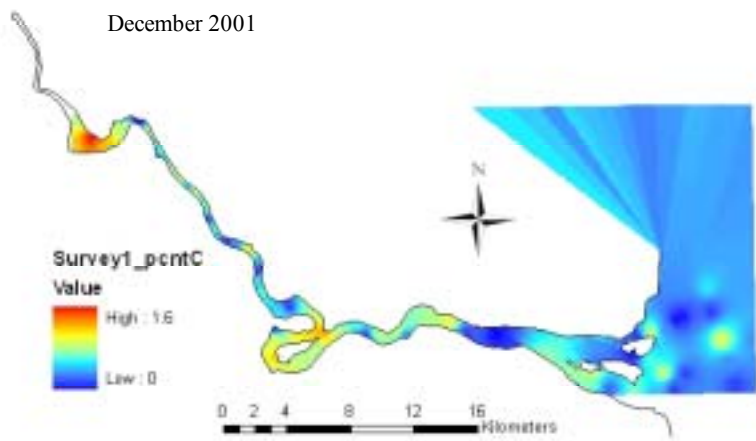

**Figure 7.** GIS interpolation of percent organic carbon (w/w dry weight) in Fitzroy sediments from all surveys.

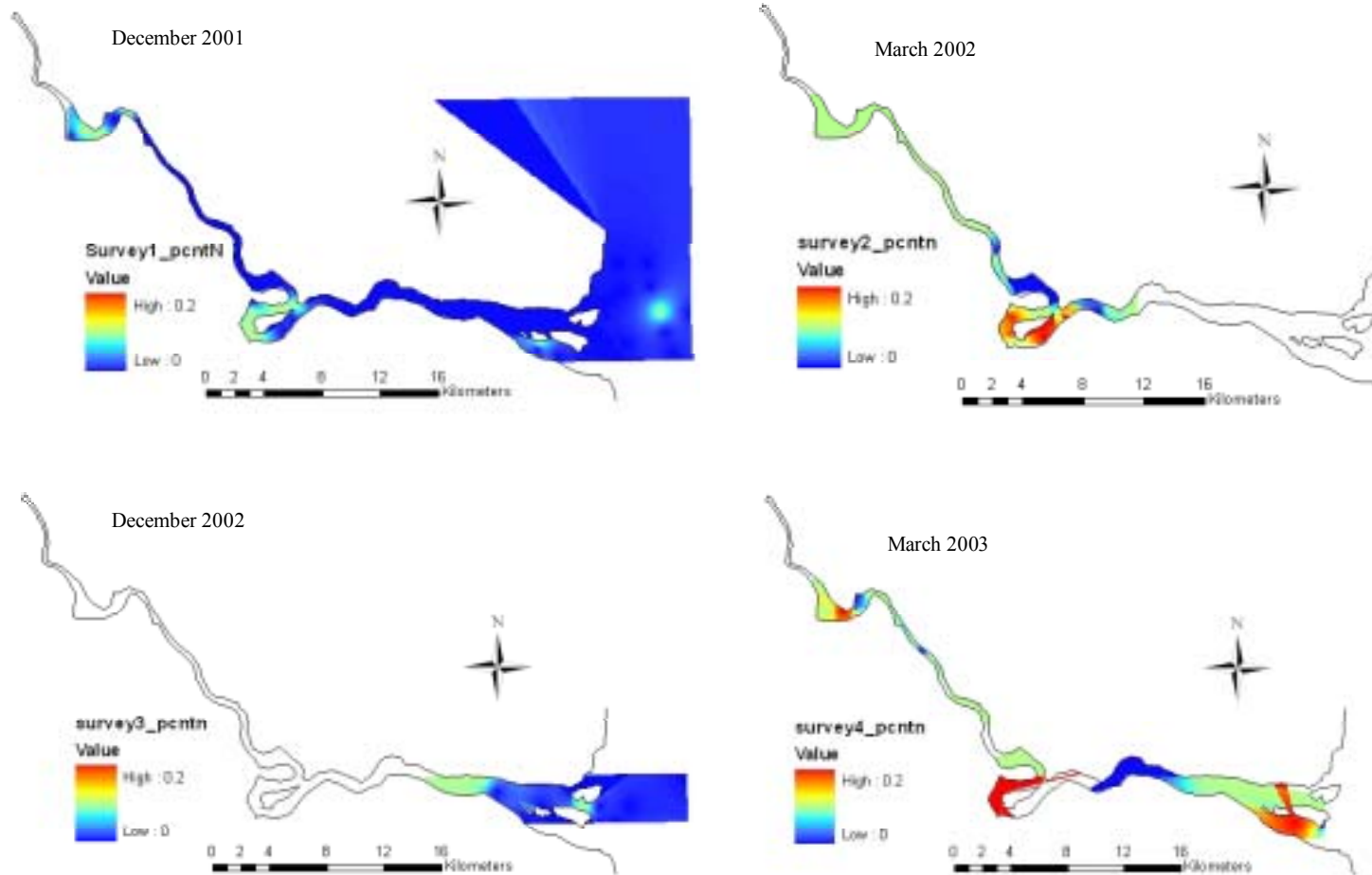

**Figure 8.** GIS interpolation of percent nitrogen (w/w dry weight) in Fitzroy sediments from all surveys.

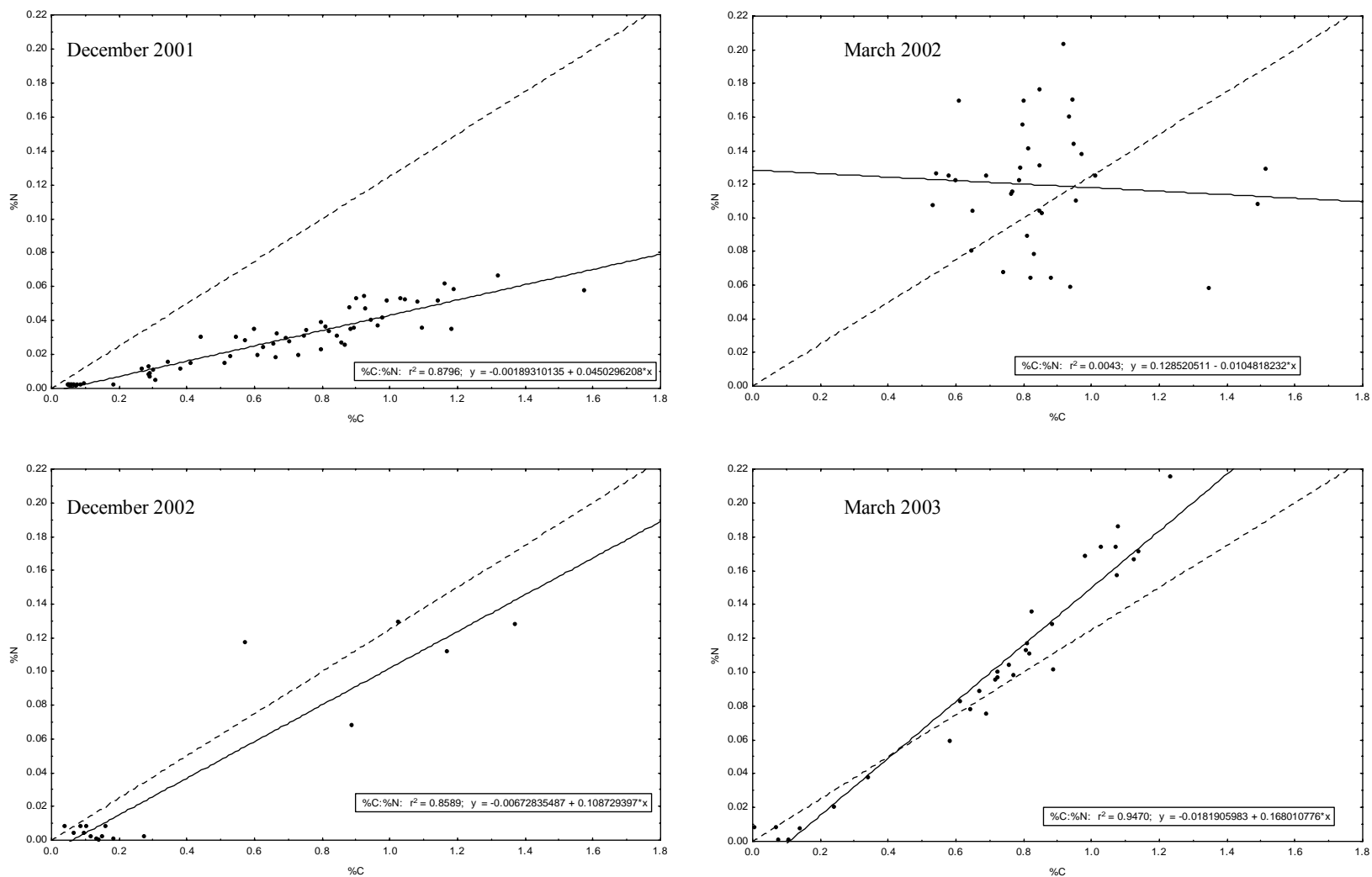

**Figure 9.** Plots of %C versus %N in Fitzroy sediments from four surveys. Dashed line represents a C:N ratio = 8.

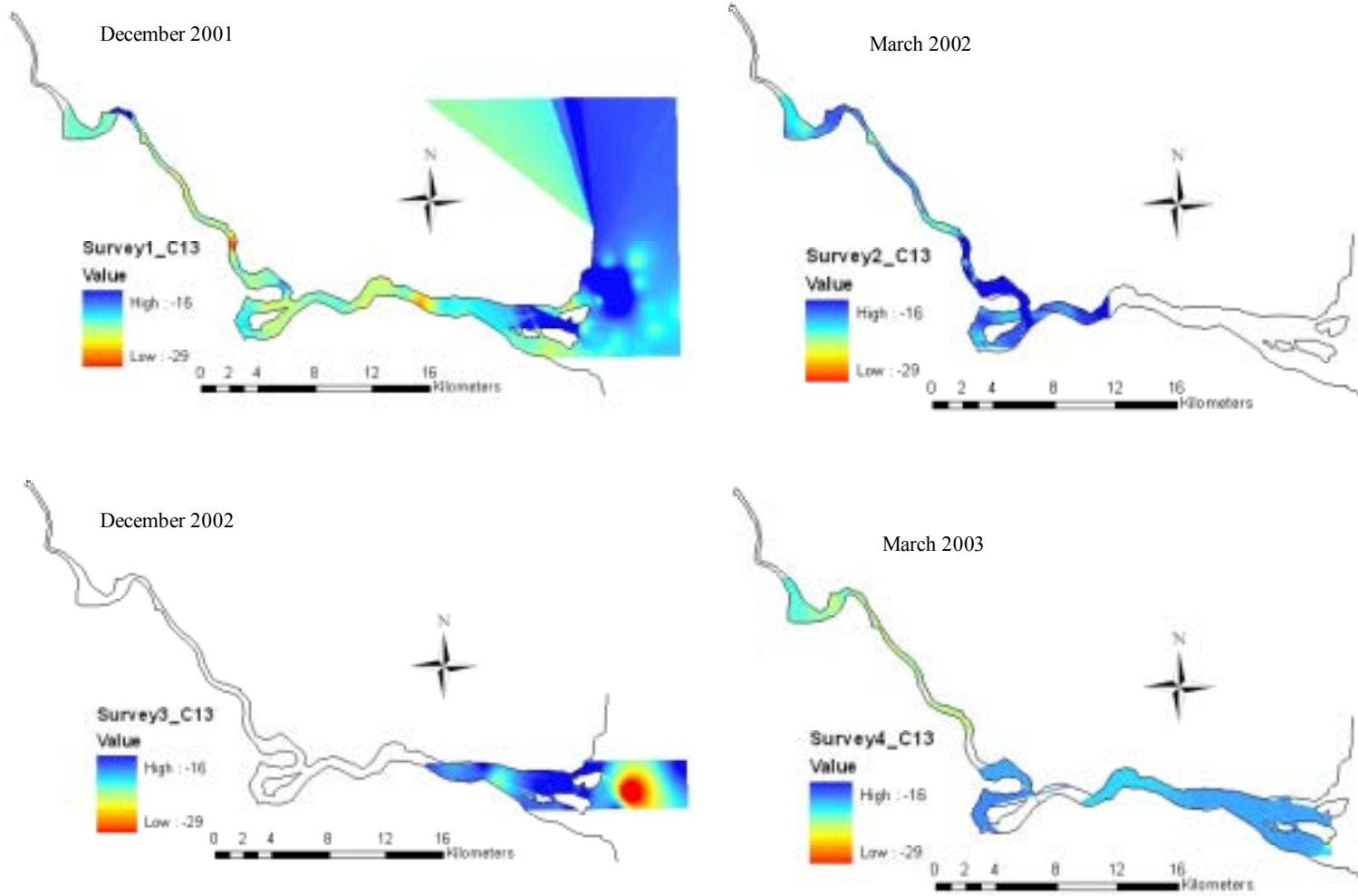

**Figure 10.** GIS interpolation of carbon stable isotope values for Fitzroy sediments from four surveys. Values are parts per thousand relative to PDB Belemnite.

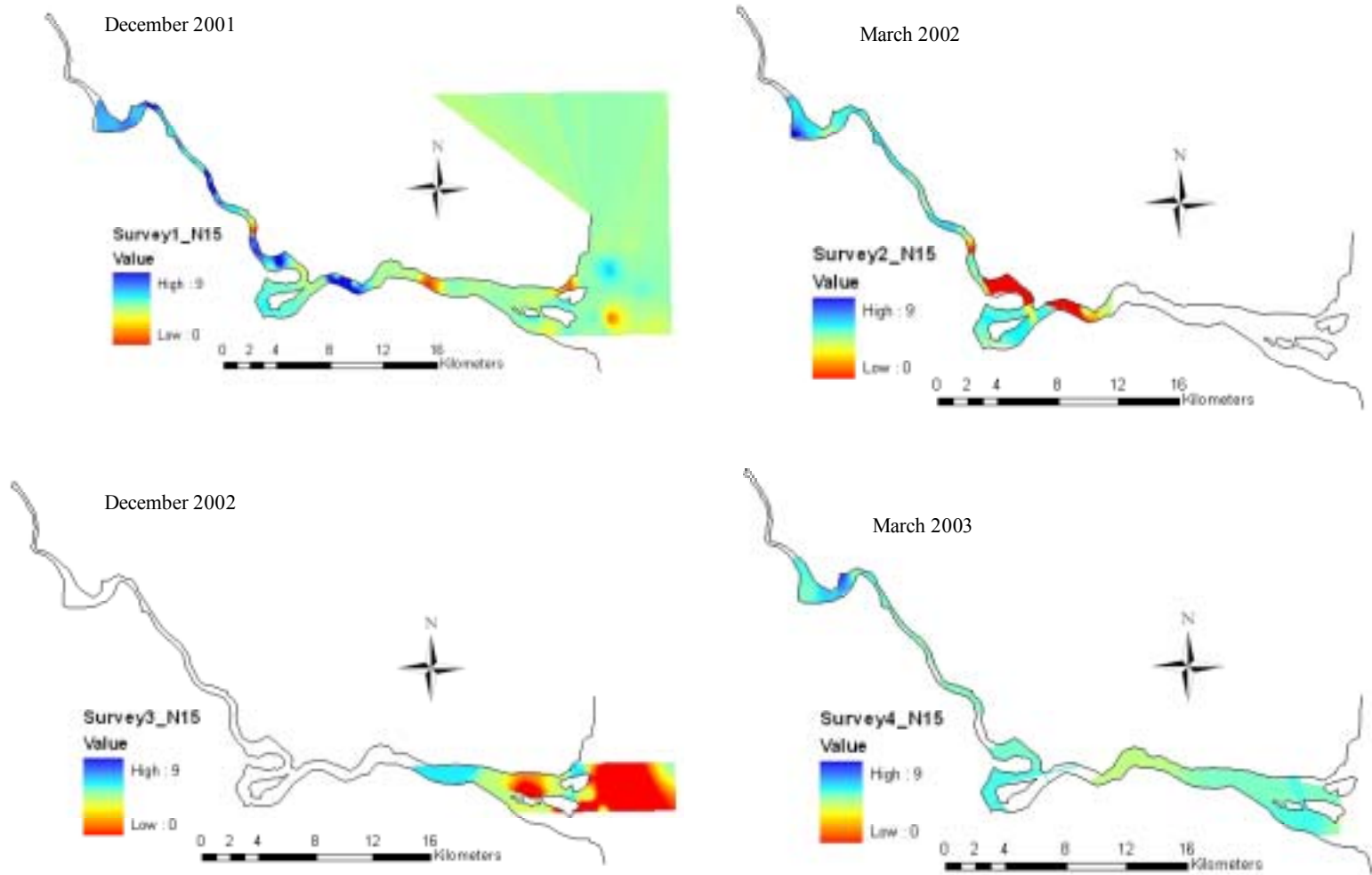

**Figure 11.** GIS interpolation of nitrogen stable isotope values for Fitzroy sediments from four surveys. Values are parts per thousand relative to atmospheric nitrogen.



A final option for investigating carbon sources to sediments is the use of chemical markers. These are compounds which can be identified in organic extracts from sediments and are known to have a particular source. Their specificity can range from broad groups such as ‘plants’ to particular families such as ‘dinoflagellates’. Three typical chromatograms from Fitzroy estuary sediments are shown in Figure 12. These are from samples taken above and below the Cut-through and within the loop which is now by-passed. The loop has quite different conditions compared to either the upstream or downstream sections of the main estuary. It has lower turbidity and is a zone of sediment deposition. It is clear that all three sites contain the same major peaks but that there are differences in the relative abundances between sites. Interestingly, all three contain phytol (Table 9) which is indicative of relatively fresh phytoplankton growth. This could be from water column productivity or benthic production on the adjacent mudflats. Interestingly, cholesterol is not the major peak in the samples. This is unusual as this is a general marker, abundant in animals, which would suggest there is little in-faunal activity within the sediments.

Stigmasterol has a reasonably major peak which, along with sitosterol, is a marker for higher plants, indicating the terrestrial nature of the organic matter. Further downstream, taraxerol becomes the dominant marker and this tends to be found in sediments associated with mangroves. This would suggest that there is some material moving from the mudflats into the main estuary. However, the stable isotope values for this material would be expected to be around -29‰, thus given the isotope signatures measured, the amount of this material contributing to the overall carbon pool of the main estuary is probably relatively small. However, it is probably an important contributor to the mudflats. Samples from below the Cut-through also have several peaks clustered around and after sitosterol (Fig. 11). These are amyryns and betulins, Mixtures of compounds which indicate a greater input from mangroves further down the estuary.

Table 9: Major peak identification for Figure 12.

Peak	Compound
1	Phytol
2	Cholesterol
3	Stigmasterol
4	Taraxerol
5	Sitosterol

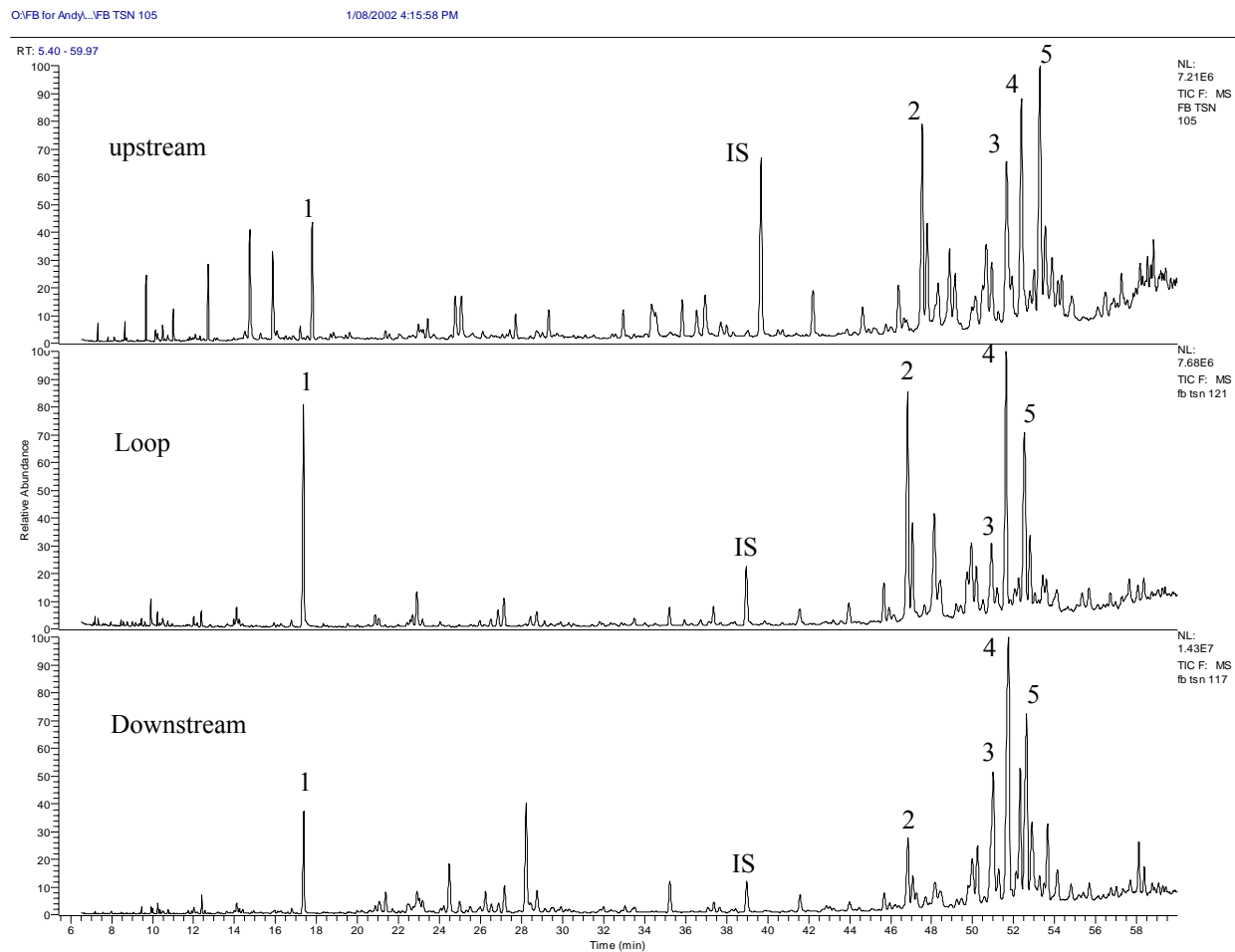

**Figure 12.** Examples of gas chromatograms of Fitzroy sediment extracts. Numbers refer to peaks identified in Table 9. IS = internal standard.

### **3.8 Conclusions**

1. Pelagic primary productivity occurs predominantly in the upper part of the estuary and reaches a maximum only when the saltwater penetrates fully into the estuary and settling of the fine particles has occurred upstream.
2. There is also primary production by microphytobenthos. This varies spatially and is dependent on the availability of intertidal mudflats.
3. The particulate organic matter delivered to the estuary is soil organic matter and relatively low in carbon and nitrogen in keeping with other tropical/sub-tropical estuaries.
4. The principal source of carbon for the main estuary is the soil organic matter from the upper catchment, but there is some input from the adjacent mudflats.
5. Inputs of nitrogen could be either terrestrial or anthropogenic mixed with some marine derived material.

It is also worth noting that during the course of this study, there was no significant rain event, so the proposed comparison of pre- and post-flood was not achievable.

More recent work conducted in Coastal CRC project AC (Coastal CRC 2003-2006) suggests that attached macroalgae may be an important (but short lived) primary producer on the intertidal areas after flood events.

## CHAPTER 4. BUDGETS FOR NUTRIENTS

### 4.1 Introduction

Most common techniques for estimating budgets within estuaries (e.g. LOICZ) rely on the estuary being in a quasi-steady state; that is, the distribution of material within the estuary is changing over timescales that are long compared to the characteristic flushing time of the estuary. The discharge of the Fitzroy is highly episodic with high discharges occurring over periods of few weeks interspersed with sometimes long periods of little or no flow. During a time of strong, steady discharge, the flushing time of the estuary may be only a few days or less and under these conditions the system is in a quasi-steady state so the LOICZ-style budget procedure can be applied. Conversely, during low or no discharge periods, the estuary gradually becomes more saline as seawater is mixed in from the sea. In this circumstance, the time scale of substance concentration change is the same as (for a conservative substance) or similar to the estuarine flushing time. The LOICZ-style procedure can be modified to account for this if it is known how the substance distributions within the estuary evolve with time. In effect, temporal changes of substance concentration, assuming conservative behaviour, can be compared to the actual changes in concentrations. Departures between expected and measured concentrations can be used to infer the sizes of internal sources or sinks.

For the Fitzroy estuary, the measurements obtained during the 22 surveys between November 2000 and July 2002 show a prolonged period of 8 months in which river discharges were less than  $1 \text{ m}^3 \text{ s}^{-1}$ . For the remainder of the time, discharges were highly variable and not constant for more than a few days at a time. This unsteadiness in discharge negates the assumptions that the distribution of material within the estuary had evolved in a regular way between sampling trips and that these distributions in-between times could be estimated by simple interpolation. This circumstance renders the regular LOICZ-style approach to estimating budgets for the Fitzroy invalid during times of variable discharge (Webster *et. al.* 2000).

Here, we estimate budgets using an approach which circumvents the difficulties associated with variable flow between sampling surveys. The method employs the fundamental principle that salinity distributions can be used to infer the mixing properties of the estuarine system as does the LOICZ approach. However, in the present method, the salinity distributions over the whole length of the study area are used to calibrate a dynamical model of mixing and exchange within the estuary and between the estuary and the adjacent coastal area. With daily river discharges as input, the model simulates the temporally variable transport properties of the estuary between survey times. Starting from the measured concentrations of a particular substance along the estuary at the time of a particular survey, the model is then used to predict how the substance concentration would evolve with time in response to long-estuary transport as well as to prescribed inputs of substance along the length of the estuary. Finally, the sizes of these inputs are adjusted so that the modelled and measured concentration distributions for the following survey match one another. Thus, this inverse method estimates the sizes of the material inflows and outflows along the estuary that are necessary to produce the measured changes in substance distribution from each survey to the next.

## 4.2. The inverse method for estimating inflows/outflows

### 4.2.1 Transport model description

A model is first developed to describe the spatial and temporal variation of a specified substance within the Fitzroy estuary. We consider the long-estuary distribution of a substance which has concentration  $c(x,t)$  where  $x$  is distance downstream from the Barrage at Rockhampton and  $t$  is time. Here, lateral and vertical variations in concentration are not considered explicitly so that  $c$  should be considered to be the concentration averaged over the cross section at distance  $x$ . Further, the variation in  $c$  due to the large longitudinal tidal excursions occurring at the semi-diurnal frequency are ignored. In effect, the concentration is also temporally averaged over its tidal variation. We further assume that longitudinal transport within the estuary can be described by the 1-dimensional advection-diffusion equation:

$$A \frac{\partial c}{\partial t} + \frac{\partial A u c}{\partial x} - \frac{\partial}{\partial x} A D \frac{\partial c}{\partial x} = \frac{S}{H} \quad (1)$$

Here,  $A$  is the cross-sectional area,  $u$  is the tidally averaged flow velocity down the estuary,  $D$  is a dispersion coefficient, and  $S$  is the source of substance per length of estuary, and  $H$  is water depth.  $A$ ,  $u$ ,  $D$ ,  $S$ , and  $H$  all vary with  $x$ . The long-estuary velocity,  $u = u(x,t)$ , is calculated from the prescribed time-varying river discharge,  $Q = Q(t)$ , which is input to the estuary at  $x = 0$  and from the cross-sectional areas along the estuary. In the calculation of  $u$ , account is also taken of evaporative losses and precipitation gains cross the water surface along the estuary.

Suppose at the time of the  $i^{\text{th}}$  survey, the concentration along the Fitzroy estuary is measured to be  $c_i(x)$ . With this concentration distribution along the estuary, Eq. 1 can be integrated forward in time to yield the concentration along the estuary at subsequent times with suitable boundary conditions. The boundary condition at the head of the estuary,  $x = 0$ , is that the downstream flow of substance is equal to that provided by the river and that the diffusive flux of substance is zero.

The downstream boundary condition is more problematic. A possible boundary condition there is the prescription of the concentration at the estuary mouth at  $x = 53$  km. However, the concentration at the mouth between surveys was not measured and is unknown. River flow events between surveys could change the concentration in a way that could deviate substantially from a simple interpolation of concentration in time. Consequently, the approach adopted was to extend the model domain from the mouth of the estuary out into the nearby coastal zone to  $x = 80$  km and to apply a constant concentration boundary condition at this distance. At  $x = 80$  km, we set  $c = c_{sea}$  where  $c_{sea}$  is the assumed seawater concentration of the substance. The underlying assumption is that the direct impact of the estuary on substance concentrations extends beyond the mouth of the estuary, but at a distance of 27 km from the mouth seawater conditions prevail. This distance was chosen as being optimal for achieving agreement between model-predicted and measured salinities near the mouth of the Fitzroy Estuary. At the beginning of the simulations, the concentrations between  $x = 53$  and 80 km were set to  $c_{sea}$ .

For the simulations undertaken, the model grid had a cell length of 1 km. In the numerical code, the advection term (2<sup>nd</sup> term in Eq. 1) and the dispersion term (3<sup>rd</sup> term in Eq. 1) were expressed in mass-conserving form. First-order upwind differencing was used for the advection term (Roache, 1982).

#### 4.2.2. Estimation of dispersion coefficient

The dispersion coefficient,  $D$ , was estimated using the salinity measurements from 22 surveys in the estuary. For a prescribed  $D = D(x)$ , Eq. 1 was integrated in time and distance to obtain predicted salinities over the duration of the study,  $s = s(x, t)$ . For each simulation, an error function was calculated as the sum of the squared differences between the average predicted and measured salinities within the estuary for the combined set of surveys. Two other error functions were calculated as the sum of the squared differences between the predicted and measured salinities at the head and the mouth of the estuary. A preliminary dispersion function along the length of the estuary was estimated on the basis of a LOICZ analysis undertaken during the 8-month period of near zero river discharge starting in April 2001. The dispersion function was 'fine-tuned' by minimising the sum of the error functions. The resulting dispersion function that was used in all subsequent simulations for the distributions of other substances within the estuary is:

$$\begin{aligned} D &= A^{-1}(28 + 7.3e^{0.123x}) \quad \text{for } x \leq 53 \text{ km} \\ D &= 11,000 \quad \quad \quad \text{for } x > 53 \text{ km} \end{aligned} \quad (2)$$

where the units of  $D$  are  $\text{m}^2\text{s}^{-1}$ , of  $A$  are  $\text{m}^2$ , and of  $x$  are km.

Figure 13 compares the measured and modelled salinities during the study period at locations in the upper estuary (8 km), mid-estuary (25 km) and in the lower estuary (44 km). The response of the salinity distribution within the estuary to river discharge events can be clearly seen as rapid drops in salinity. Overall the modelled salinities and the salinities measured during the surveys match one another reasonably well. Probably the most significant departure between simulation and measurement occurs after the discharge event of January 2002. Even though the model predicts the average measured salinity in the estuary well through this period, the salinity near the mouth is over predicted, whereas the salinity near the barrage is somewhat under-predicted. Between November 2000 and February 2001, there are three major discharge events which caused significant reductions in salinity along the estuary. In between events, the mid-estuary salinity and the salinity near the mouth recover significantly. The problem of representing the salinity near the mouth between surveys is exemplified here. The salinities measured at the mouth on 13 December 2000, 18 January 2001, and 21 February 2001 were 14.6, 16.2, and 11.3 ppt, respectively, values which are consistent with model predictions on these dates. However, between these survey times the modelled predicted salinities varied between 1.2 and 25.4 ppt. Linear interpolation between these survey times would show a salinity variation of less than 5 ppt, but the real variation was probably more than 20 PPT.

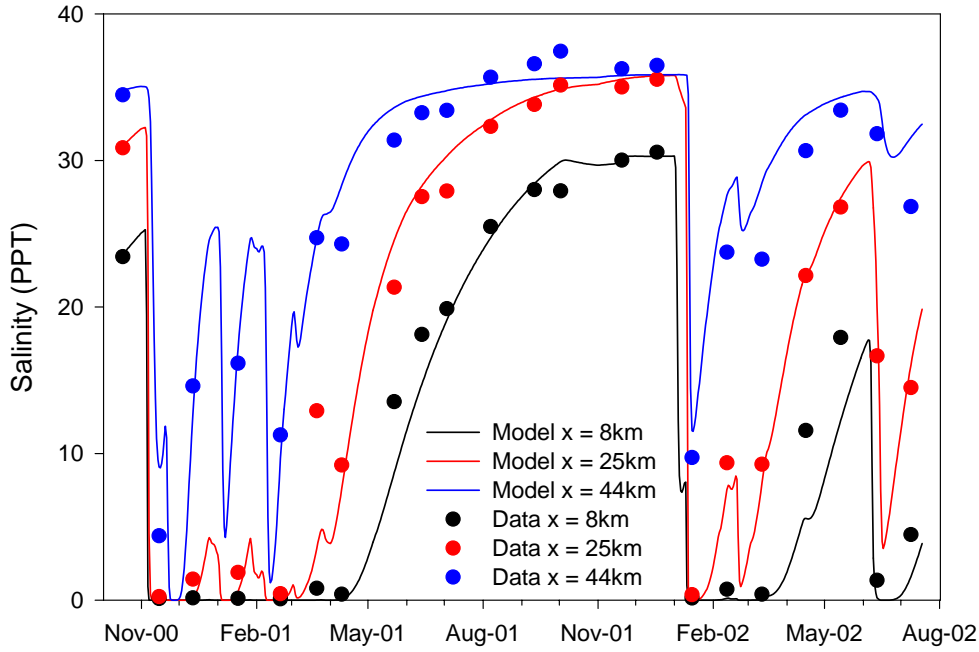

**Figure 13.** Modelled and measured salinities compared for locations at the upper, mid-point and mouth of the Fitzroy estuary.

#### 4.2.3. Estimation of internal loading/losses

Equation 1 can also be used to describe the transport and distribution of substances other than salt along the estuary. In this case, the internal sources and sinks of substance are unknown and are determined using the following inverse procedure. The estuary is divided up into a series of six contiguous cells along its length. The boundaries of the cells are specified in Table 10. The area and volume of the Loop are included in cell number 4. Within cells 2 to 6, we assume that the internal input/output flux is uniform along the length of each cell and is constant between survey times. The input into cell 1, which is the cell receiving the river discharge and the discharges from the wastewater treatment plants, is handled differently. First, we consider the contribution of the internal flux to an individual cell to the overall concentration distribution in the estuary. If  $x_i^u$  is the upstream coordinate of the cell  $i$  and  $x_i^d$  is its downstream coordinate and suppose the flux into the cell has unit magnitude then the flow of material into the estuary per unit length is:

$$S^i = w \quad x_i^u \leq x \leq x_i^d \quad (3)$$

$$= 0 \quad \text{elsewhere}$$

where  $w$  is the width of the estuary at position  $x$ . For cell 1, the substance inflow is assumed to derive from the river and to occur at  $x = 0$ . Furthermore, the mass loading rate is assumed to be proportional to the discharge of the Fitzroy River. With a nominal unitary concentration in the inflow, the riverine mass inflow is:

$$M = Q \quad (4)$$

For all six cells, let the concentration along the estuary at the time of the  $n^{\text{th}}$  survey due to the contribution from the  $i^{\text{th}}$  cell be initially zero. That is:

$$c_m^i(x, t_n) = 0 \quad (5)$$

where the subscript 'm' stands for 'modelled'. Then Eq. 1 can be integrated with time and distance to yield a concentration distribution along the estuary at the time of survey  $n+1$ . Let this solution be  $c_m^i(x, t_{n+1})$ . We construct these six solutions for individual inputs to cells 1 to 6. There is also a homogeneous solution that represents how the concentration measured at time  $t_n$  would evolve if all the internal inputs were set to zero. This solution at the time of survey  $n+1$  would be  $c_m^0(x, t_{n+1})$ .

The total model solution at  $t_{n+1}$  can be constructed as the sum of the homogeneous solution and the solutions having inputs in the 6 sections of the estuary; that is:

$$c_m = c_m^0 + \sum_{i=1}^6 \alpha_i c_m^i \quad (6)$$

where the coefficients  $\alpha_i$  remain to be determined. We define an averaging procedure for concentrations along the estuary such that  ${}^j\bar{c}$  represents the average concentration in cell  $j$ . Let subscript  $d$  represent measured concentration at time  $t_{n+1}$ . We specify that for each cell along the estuary the average measured and modelled concentrations in each cell are equal at time  $t_{n+1}$  so that  ${}^j\bar{c}_m = {}^j\bar{c}_d$ . With Eq. 6, the following six coupled equations result:

$$\begin{aligned} {}^1\bar{c}_m^0 + \sum_{i=1}^6 \alpha_i {}^1\bar{c}_m^i &= {}^1\bar{c}_d \\ \cdot & \cdot \\ \cdot & \cdot \\ {}^6\bar{c}_m^0 + \sum_{i=1}^6 \alpha_i {}^6\bar{c}_m^i &= {}^6\bar{c}_d \end{aligned} \quad (7)$$

These equations are solved to yield the six coefficients  $\alpha_i$ . For cells 2 to 6, the  $\alpha_i$  are the fluxes into each cell expressed as material flow per unit surface area. For cell 1,  $\alpha_1$  is the concentration of substance in the river discharge so that  $\alpha_1 Q$  is the instantaneous load.

Table 10. The boundaries and dimensions of the cells used in the inverse analysis.

Cell No.	Cell start (km)	Cell end (km)	Cell surface area ( $\times 10^6 \text{ m}^2$ )	Cell volume ( $\times 10^6 \text{ m}^3$ )
1	0	8	1.9	8.9
2	8	18	3.2	17.1
3	18	25	3.0	17.1
4	25	34	9.7	49.6
5	34	44	9.3	62.9
6	44	53	16.6	90.7



## 4.3 Nitrogen

### 4.3.1 Imports/Exports

We consider first the loads of nutrients being imported into the estuary and exported at the seaward end. The riverine input is taken to be the computed load into cell 1. This is reasonably accurate for discharges greater  $\sim 5 \text{ m}^3\text{s}^{-1}$ , but for lesser discharges the input/output into the first cell may be dominated by internal processes. Rather than use the outflow from cell 6 to estimate nutrient discharge from the estuary, we use the outflow from cell 5. For all nutrients, the downstream export from cell 5 appeared to be more stable than those computed from cell 6. The downstream side of cell 6 is the seaward extent of the measurements and model predictions would be less constrained there than they would in the interior of the estuary.

Figure 14 shows the import and export results for Total Nitrogen (TN). Each bar represents the import/export calculated between successive pairs of surveys. River imports are shown for average river discharges (average between surveys)  $> 5 \text{ m}^3\text{s}^{-1}$  since it is only for these discharges that the river dominates inputs of TN. For lesser discharges, the combined inputs from cells 2 and 3 are shown since these were dominant at times of lower river flow.

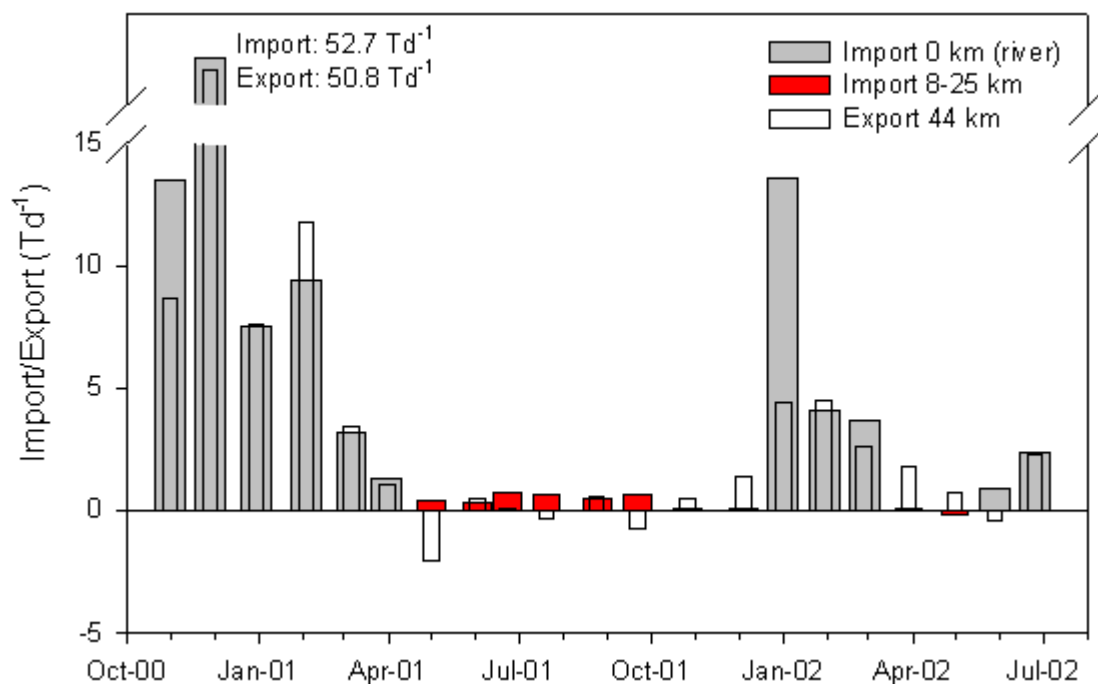

**Figure 14.** TN imports and exports from the Fitzroy estuary. Imports are shown as river inputs for  $\bar{Q} > 5 \text{ m}^3\text{s}^{-1}$  and for the import from cells 2 and 3 combined for  $\bar{Q} < 5 \text{ m}^3\text{s}^{-1}$ .

It is apparent that over the 630-d period of the study that the TN inputs to the estuary are very much dominated by the river flow events. The effective inflow TN concentrations varied between  $0.5\text{-}1.5 \text{ mgL}^{-1}$  so that most of the variation in riverine load is due to variation in average discharge between surveys. Through the first summer of the study, October, 2000 to April 2001, the total input by the river to the estuary is estimated to be 2,520 t of which 2,420 t was exported downstream of  $x = 44$

km Almost half of this input load during the first summer was delivered to the estuary over a 10 day period near the end of November 2000. The following summer (2001/2002) the total input is calculated to be 600 t which is a factor of more than four smaller. The 320 t exported the following summer (2002/2003) is about half the import for the same period. Note that the import to the estuary in November 2000 and January 2002 exceeds considerably the export for the same time period. The volume of river water discharged into the estuary at these times was similar to the estuarine volume so that the through-flow was not as large as it would have been if the estuary was already filled with river water.

For the low flow period between May-December, 2001, the combined input from cells 2 and 3 (8-25 km) was always positive with an average load of  $420 \text{ kgd}^{-1}$  and an expected error in the mean of  $110 \text{ kgd}^{-1}$ . Over this period, input from this part of the estuary contributed a total of  $95 \pm 25 \text{ t}$  of TN, but the calculated outflow from cell 5 was  $-20 \text{ t}$ ; that is, there was a net inflow at this distance. Considering the variation in calculated export during the low flow period, an import of  $-20 \text{ t}$  is not statistically different from zero import/export.

Table 11 provides the composition of the imports/exports. Particulate nitrogen (PN) is calculated as the difference between measured TN and dissolved N (DN). Dissolved inorganic nitrogen (DIN) is the sum of NO<sub>x</sub> and ammonia, whereas dissolved organic nitrogen (DON) is DN - DIN.

Table 11. Summary table for imports and exports of nitrogen species during the period of elevated flow November 2000 - April 2001 and for the low flow period May-December 2001. Imports during the elevated flows are from the river and for the low flow period these are internal inputs from cells 2 and 3. Units are tonnes (t).

<b>Period</b>	<b>Total (t)</b>	<b>PN (t) (%)</b>	<b>DON (t) (%)</b>	<b>DIN (t) (%)</b>
River import Nov. '00-Apr.'01	2,520	570 (23)	1210 (48)	740 (29)
Estuary export Nov. '00-Apr.'01	2,420	510 (21)	1090 (45)	820 (34)
Estuary import May-Dec. '01	95	-3 (-3)	15 (16)	83 (87)
Estuary export May-Dec. '01	-20	-132	60	52

During the high flow period, November 2000 to April 2001, almost half of the TN discharged into the estuary by the Fitzroy River is DON (48%), whereas the export proportion is somewhat less at 43%. The next largest constituent of TN is DIN which contributes about 30% of both imported and exported TN followed by PN which contributes ~20% of imported and exported loads. It is likely that the proportions of constituents in the imported and exported loads are not significantly different from one another. Thus, during this time of elevated discharges the Fitzroy is behaving very much as a channel: the majority of the TN imported into the estuary is exported out the other end without major changes in composition.

During the period of low flow, May-December 2001, the major source of TN to the estuary is internal, occurring as input into cells 2 and 3 (8-25 km downstream from head). Most of the input nitrogen (~90%) is estimated to be DIN in contrast to the ~30% DIN composition in the riverine load. It is likely that much of these discharges derive from the domestic sources and meatworks located within this section of the estuary. The nominal annual discharge of TN from the STP is 75 t most of which would be expected to be DIN. The composition of the inflow to these cells is approximately 40% NO<sub>x</sub> and 60% ammonia. During this low flow period, the analysis shows an export of DIN+DON downstream from cell 5 (112 t) which is similar to the internal source in cells 2 and 3 (98 t). The net import of TN to the estuary at this distance is due to a calculated import of PN which more than balances the export of DIN+DON. However, the lower sections of the estuary are subject to large currents and significant amounts of resuspension and settling of sediments (and other kinds of particulate matter) over the tidal cycle. Possible temporal variations in PN concentrations over the tidal cycle would compromise the accuracy of the estimates of PN exports.

#### 4.3.2 Internal budgets

Figure 15 shows the nitrogen budgets for the low-flow period May-December, 2001. The results are amalgamated into two compartments – cells 2 and 3 together representing the upper end of the estuary and cells 4 and 5 representing its lower end. The input into cells 2 and 3 from upstream could derive from either the river or internal sources in cell 1. For clarity of exposition cell 1 (inflow) and cell 6 (outflow) are omitted from Figures 15 and 17. River discharges were measured at the Gap which is ~100 km upstream of the barrage. The discharges measured during this time had an average of only 0.5 m<sup>3</sup>s<sup>-1</sup>. Assuming a nominal TN concentration in the river flow of 1 mgL<sup>-1</sup>, the TN discharged into the head of the estuary by the river over the 224 days of low flow would have been 10 t, whereas the combined inflow of PN, DON, and DIN into cells 2 and 3 is 22 t (Fig. 14). Given that the discharge has not been measured at the Barrage and given the likely large relative errors in measuring low discharges (at the Gap), it is not clear whether the river contributes the major part of the upstream input to cells 2 and 3 or not. Cell 4 includes the Loop, a section of the estuary that was originally the main channel, but which is now been pinched off and effectively represents a side embayment. The Loop has a large surface area but is relatively shallow due to sediment deposition under the reduced flow speeds that have prevailed since it has been bypassed by the main channel.

In Figure 15, we show diagrammatically an internal budget for chlorophyll *a*. This has been developed from the PN inputs and outputs of the different cells taking the mass ratio of nitrogen to chlorophyll is 7 and assuming the PN to be a surrogate for phytoplankton nitrogen. The PN input into cells 2 and 3 appears to be mainly chlorophyll which could be either washed through the barrage or which may be due to phytoplankton production in cell 1. Through cells 2 and 3 there is further input 7 t of chlorophyll added. This is produced through phytoplankton growth within these cells which is all exported downstream along with the upstream input (4 t inflow from cell 1). In cells 4 and 5 chlorophyll (16 t) is lost from the system. It would appear that phytoplankton growth is inhibited in the lower parts of the estuary due to the high turbidity and is insufficient to replace losses such as due to settling. The PN exported downstream from cells 2 and 3 (9 t) is largely accountable by the nitrogen associated with chlorophyll, but in cells 4 and 5 the analysis suggests that there is a large input of

**PN**

**Chlorophyll**

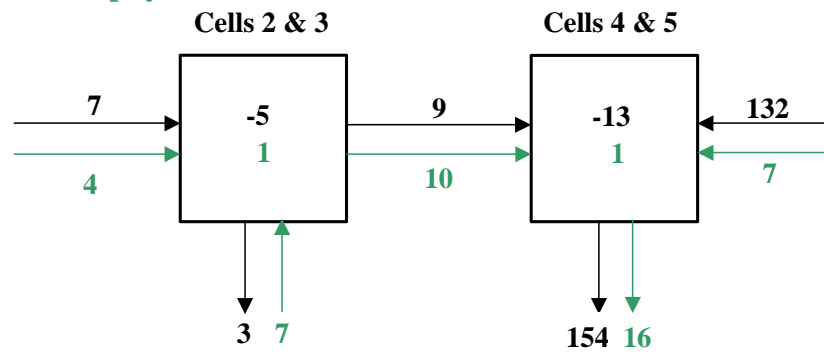

**DON**

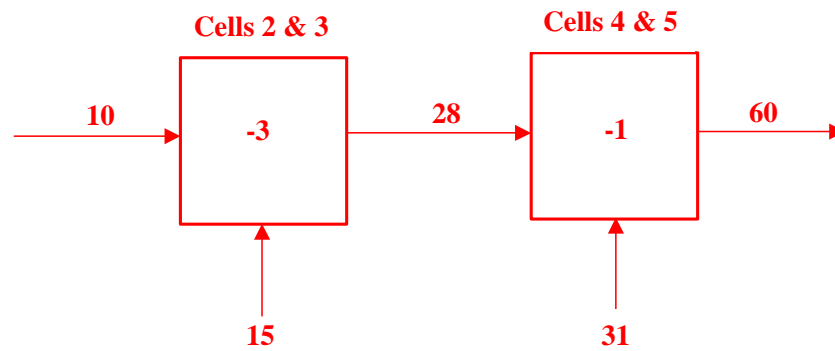

**DIN**

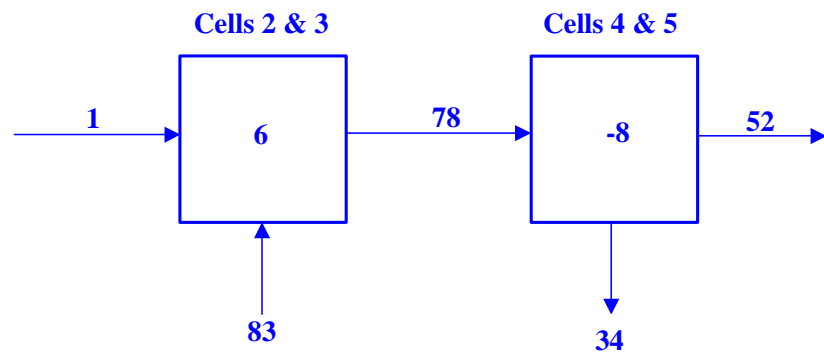

**Figure 15.** Nitrogen budgets for low-flow period May-December 2001. Units are tonnes of nitrogen. The numbers within the boxes are the changes in the water column 'store' over this time. Horizontal arrows indicate net transfer of material between cells, while vertical arrows indicate net transfer of material, either into (upward arrow) or out of (downward arrow) the cell **from** the sediments.

PN from the lowest part of the estuary (132 t) which is lost internally in cells 4 and 5 perhaps through settling in the Loop or in other parts of the estuary.

For DON, there are significant internal sources for both pairs of cells as well as an input from upstream. Consequently, the down-estuary transport of DON increases along the length of the estuary and 60 t of DON is exported to the lower end of the estuary. The store of DON within the estuarine water column reduces by an estimated 4 t, whereas the combined inputs to cells 2-5 is 56t (10 +15 +31 t). Possible sources of DON within the estuary are the decomposition/mineralisation of organic matter either deposited during the high discharge times either within the estuary or in the mouth into Keppel Bay, or DON export from the intertidal wetlands along the banks of the estuary.

The budget analysis indicates that little DIN is imported into cells 2 and 3 from upstream during the low flow period (1 t). As indicated previously, there is a significant source of DIN in the estuary to cells 2 and 3 (83 t) which we have postulated to be due, in part, to discharges from the meatworks. Most of the DIN input to cells 2 and 3 (78 t) is exported downstream to cells 4 and 5. About 65% of the 78 t of DIN imported from upstream to cells 4 and 5 is exported to the lower end of the estuary (52 t) and most of the rest is lost internally (34 t). If the DIN lost internally is assumed to be lost due to denitrification, then this loss of DIN over 224 days implies an average areal denitrification rate of  $0.01 \text{ g(N) m}^{-2} \text{ d}^{-1}$  which is relatively small.

## 4.4 Phosphorus

### 4.4.1 Imports/Exports

Figure 16 shows the import and export results for Total Phosphorus (TP) plotted in a manner which is consistent with the results shown in Figure 14 for TN, although note that the scale is reduced by a factor of two.

As with TN, the TP inputs to the estuary during the study period are very much dominated by river flow events. The calculated effective concentration of TP in the inflow varied between  $0.15\text{-}0.55 \text{ mgL}^{-1}$  during the times of elevated discharge  $\bar{Q} > 5 \text{ m}^3 \text{ s}^{-1}$ . Through the first summer of the study, October 2000 to April 2001, the total input of TP by the river to the estuary is estimated to be 980 t of which 760 t was exported downstream of  $x = 44 \text{ km}$ . The following summer the total input was calculated to be 200 t of which only 60 t was exported.

For the low flow period between May-December 2001, the combined input from cells 2 and 3 (8-25 km) was mostly positive with an average load of  $50 \text{ kg d}^{-1}$  and an expected error in the mean of  $20 \text{ kg d}^{-1}$ . The calculated input of TP from cells 2 and 3 during this low flow period is  $12 \pm 5 \text{ t}$  of TP and there is a further inflow into the estuary of 7 t at a downstream distance of 44 km. As with TN, there are likely to be errors in these calculations of import and export due to deposition and resuspension of the fine sediments and particulate organic matter to which a proportion of these nutrients are attached over the tidal cycle.

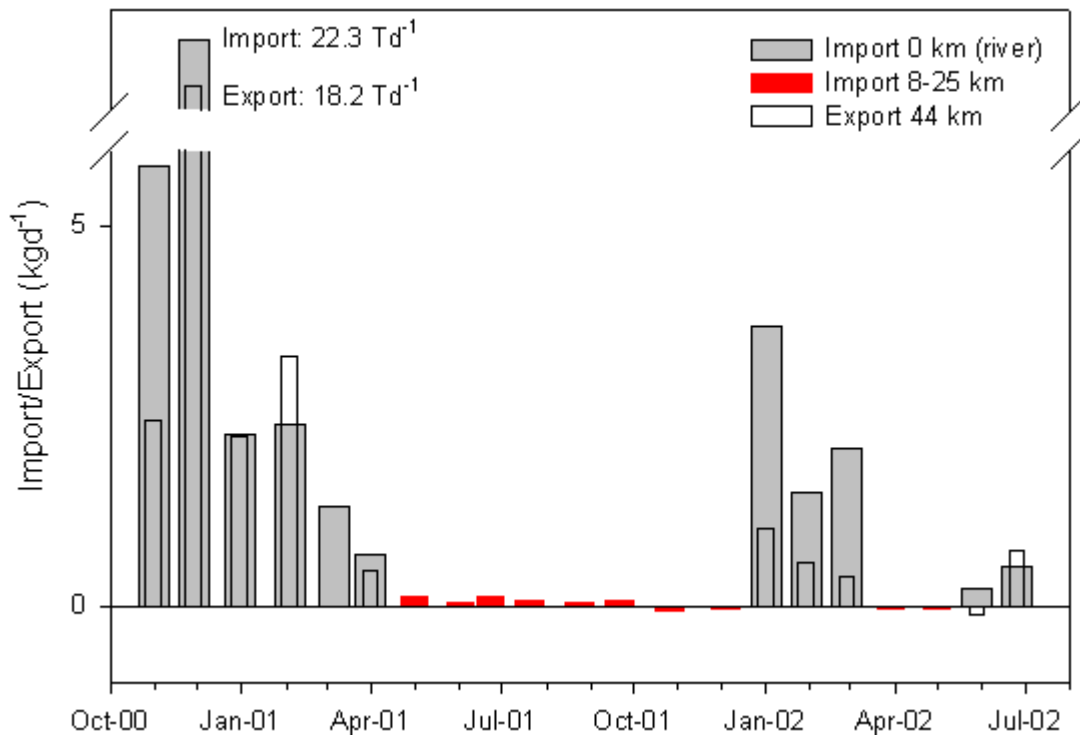

**Figure 16.** TP imports and exports from the Fitzroy Estuary. Imports are shown as river inputs for  $\bar{Q} > 5 \text{ m}^3 \text{ s}^{-1}$  and for the import from cells 2 and 3 combined for  $\bar{Q} < 5 \text{ m}^3 \text{ s}^{-1}$ .

Chemical analysis was undertaken for Filterable Reactive Phosphorus (FRP) on samples collected from June 2001 onwards. Consequently, estimates of FRP fluxes are available for most of the low-flow period May-December 2001, but not for the periods of high flow prior to this time. During the low-flow period June-December 2001, the average inflow of FRP from cells 2 and 3 was  $40 \text{ kgd}^{-1}$  which is similar to the TP load during the same period of  $45 \text{ kgd}^{-1}$ . The export of FRP out of the estuary downstream from cell 5 (44 km) during the low-flow period was for a total of 24 t. The export of TP during the same time was 2 t. As with nitrogen, the estuary appears to be more efficient at exporting dissolved inorganic phosphorus than it is with the particulate forms.

#### 4.4.2 Internal budgets

Figure 17 shows the internal phosphorus budgets for the low-flow period June-December, 2001. As with nitrogen, the results are amalgamated into two compartments – cells 2 and 3 together representing the upper end of the estuary and cells 4 and 5 representing its lower end. The input of TP from upstream of cells 2 and 3 is similar to the internal input to these cells. Since the riverine input of TP to the upstream end of the estuary (cell 1) is likely to be small, it would seem that most of the TP input to the upstream cell is internal. Further, most of this input to cell 1 and the internal input to cells 2 and 3 is due to FRP.

The combined FRP input to cells 2 and 3 is 8 t over the low-flow period, but contributions from these two cells are quite different: cell 2 contributed 14 t during this time, whereas cell 3 showed an internal loss of 6 t. The respective numbers for the dissolved inorganic form of nitrogen (DIN) into these cells were 52 and 31 t for the

### TP

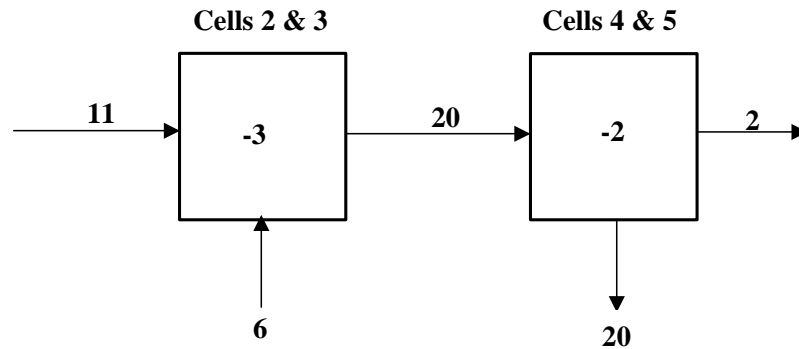

### FRP

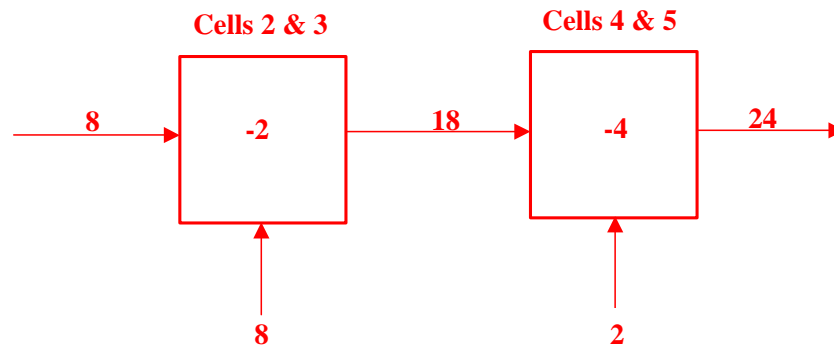

### Chlorophyll

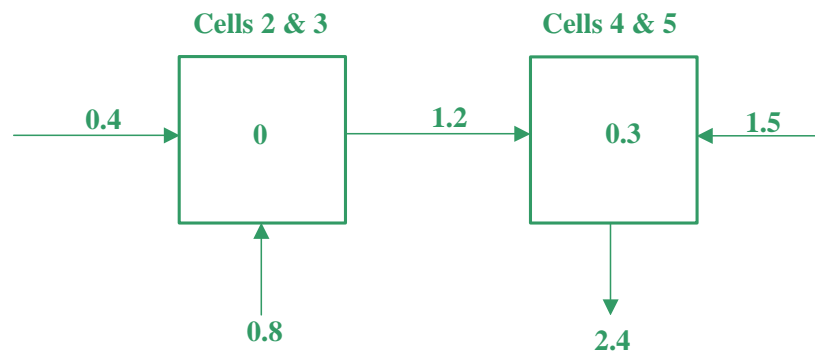

**Figure 17.** Phosphorus budgets for low-discharge period May-December 2001. Units are tonnes of phosphorus. The numbers within the boxes are the changes in the water column 'store' over this time. The numbers within the boxes are the changes in the water column 'store' over this time. Horizontal arrows indicate net transfer of material between cells, while vertical arrows indicate net transfer of material, either into (upward arrow) or out of (downward arrow) the cell **from** the sediments.

low-flow period so that the behaviour of nitrogen and phosphorus sources/sinks through the upper half of the estuary are quite different from one another. A major difference between the dynamics of nitrogen and phosphorus is the tendency of phosphorus to adsorb to fine sediments. Payne *et al.* (1998) have investigated the interaction between dissolved phosphorus and suspended sediments in the Fitzroy estuary and found that even though ionic strength did not appear to significantly alter the adsorption properties, pH did. Whether the apparent loss of FRP in cell 3 is due to a pH effect on adsorption requires further investigation.

The budget calculation shows that 20 T of TP was transported downstream from cells 2 and 3 to cells 4 and 5 and that most of this is FRP. However, in cells 4 and 5, most of the TP transported downstream is lost internally, whereas most of the FRP is transported further downstream towards the mouth of the estuary. The tendency of the system to export the dissolved inorganic form of phosphorus and to retain the sum of the particulate and dissolved organic form is consistent with what happens to nitrogen at the downstream end of the estuary.

That part of the phosphorus budget associated with chlorophyll has a magnitude of about 10% of the TP and FRP budgets. The part of the nitrogen budget associated with chlorophyll budget has a similar relative size to the other components of the nitrogen budget. Thus, phytoplankton production plays a fairly minor role in the cycling of nutrients in the estuary during times of low flow. The role of benthic primary production on the intertidal areas is not known, but could very well be much more important than pelagic primary production.

## 4.5 Silica

### 4.5.1 Imports/Exports

Measurements were made of silica (expressed as SiO<sub>2</sub>) concentrations along the estuary on 12 surveys between October 2000 and September 2001. The import and export results for silica for this period are shown in Figure 18. During the high-flow period to May 2001, the calculated silica concentrations in the river inflow to the estuary varied by less than a factor of two between 6.3-11.1 mgL<sup>-1</sup> so that the variation in silica load to the estuary was dominated by changes in discharge. As with TN and TP, the silica load delivered by the 10-day flow event in late November 2000 accounted for about half the total input to the estuary in the first summer of the study.

In contrast to TN and TP, the silica inputs from cells 2 and 3 to the estuary during the low-flow period post May 2001 were small and statistically insignificant. Consequently, these have not been shown in Figure 18. Most of the export of silica from the estuary follows its input. The input of silica integrated between October 2000 and September 2001 is 25,600 t and the integrated export is 24,200 t. Virtually all the silica imported to the estuary appears to be exported; the internal sources/sinks are too small to be resolved.



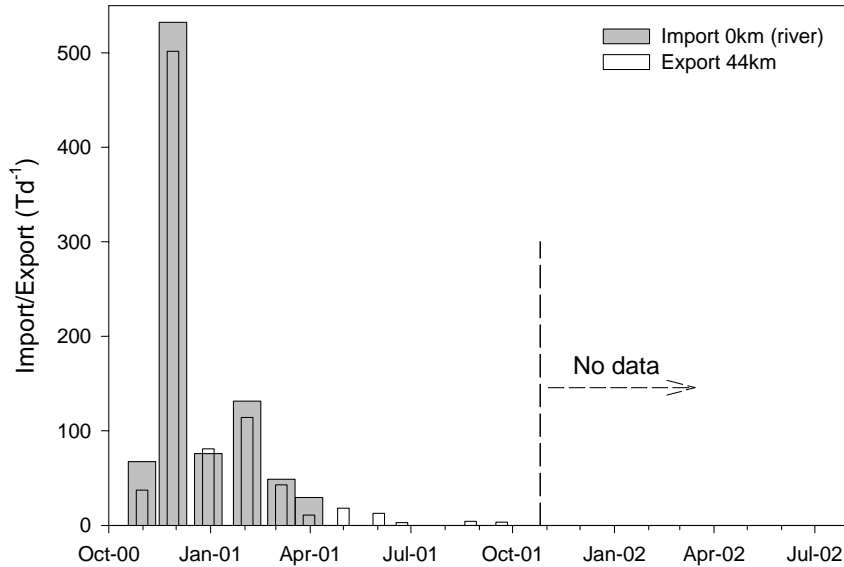

**Figure 18.** Silica imports and exports from the Fitzroy Estuary. Imports are shown as river inputs for  $\bar{Q} > 5 \text{ m}^3 \text{ s}^{-1}$ .

## 4.6 Carbon dynamics

### 4.6.1 Introduction

Earlier parts of this chapter discuss the quantity of nutrients (N, P and Si) delivered from the catchment to the estuary under both low and high flow conditions. In addition, we made quantitative estimates of the amounts of different materials which are transformed and transmitted through the estuary under the low and high flow conditions. In this section we report on the nature of organic carbon delivered from the catchment (allochthonous carbon). This chapter is complementary to the earlier Chapter 3 which focused on sources of organic carbon within the estuary. This catchment organic material, when it enters the estuary undergoes (in part) metabolism and becomes mixed with new organic matter produced *in situ* (autochthonous carbon). This organic matter is produced by several different producers: microphytobenthos, pelagic phytoplankton, mangrove detritus and the microbial loop operating in both the sediments and the water column (Fenchel *et al.*, 1998). The spatial distribution of the various producers is highly non-uniform reflecting the differences in substrate, light climate and morphology along the estuary. The character and quantity of organic matter determines the amount of energy which can be transmitted up the food chain and thus the quantity of higher organisms such as prawns and fish which give the estuary its perceived economic and recreational value. Consequently, we have put in a considerable effort to understand aspects of carbon cycling within the estuary. In this section we first briefly discuss the sources of carbon from the catchment and then go on to a more detailed exploration of the relative contributions of the different autochthonous carbon sources within the estuary.

### 4.6.2 Carbon imports from the catchment and exports from the estuary

Organic carbon is delivered to the estuary as both particulate (Particulate Organic Carbon; POC) and dissolved (Dissolved Organic Carbon: DOC) forms. The catchment is clearly the major source of both particulate and dissolved organic matter. The inputs of DOC from the Rockhampton wastewater treatment plants are minor (but continuous) in comparison to the episodic flood inputs from the catchment. The

contributions of other potential sources are discussed in Chapter 3. Measurements of surface concentrations of POC and DOC were made at 12 locations in the estuary during 24 surveys from October 2002 to October 2004. The budget methods developed during the project were applied to both POC and DOC and the results are discussed in detail elsewhere (Ford *et al.*, 2005). In brief, under low flow (dry season) conditions, the estuary is a source of DOC to Keppel Bay with the lower estuary being a bigger contributor than the upper estuary. In the wet season (high flow) the estuary acts as a conduit for most of the incoming DOC, with only small amounts being consumed in the estuary by microbial action, or converted into POC by flocculation of the dissolved material by the increasing salinity. In the wet season the estuary is a source of POC reflecting the resuspension of sediments 'pumped' back into the estuary. In the dry season the estuary is a much smaller net source of POC due to inputs of resuspended material from Keppel Bay, and augmented by *in situ* organic matter production and adsorption of DOC by resuspended particles.

Anecdotal accounts suggest that flood events move large rafts of para grass (an introduced pasture species) from the freshwater reaches upstream of the barrage, through the estuary, into Keppel Bay. We have not been able to quantify these deliveries, and thus the estimated input of POC into the estuary from the Fitzroy is an under-estimate. The soil organic matter travels with the fine sediment particles. If, as has been suggested, the sediment delivery has changed substantially since the arrival of Europeans, then the supply of particulate organic matter will have changed over the same time scale. The present day load of dissolved organic carbon is comparable to loads of particulate organic carbon. Given that there has been major changes in vegetation throughout the catchment with grasslands replacing trees and shrubs it is probable that the DOC load has also increased since European settlement.

## CHAPTER 5. THE DELIVERY OF PESTICIDES TO THE FITZROY ESTUARY AND PERSISTENT ORGANIC POLLUTANTS IN THE FOOD CHAIN

### 5.1 Introduction

There is presently a strong interest in the delivery of contaminants from terrestrial sources to the Great Barrier Reef lagoon by flood flows. In 2001 the Great Barrier Reef Ministerial Council called for information on the impacts of declining water quality entering the Great Barrier Reef lagoon and for actions to reduce the threat. Recently the Fitzroy River basin has been identified as a priority catchment in this process, particularly in respect to sediment and nutrient export to the Great Barrier Reef lagoon.

The conventional wisdom has been that the Fitzroy River catchment does not contribute substantial loads of pesticides to the estuarine and inshore marine systems. This view could appear realistic because of the relatively small area (around 7%) of the catchment used for intensive cultivation compared to grazing which is the major land use (around 80%). However, low concentrations of some herbicides were recently detected in sediment samples near the mouth of the Fitzroy River (Haynes *et al.*, 2000a). Pesticides have been detected also in water and sediment samples from a number of sites in the Fitzroy catchment via ambient (low or no-flow) monitoring programs conducted by various groups and agencies in the past (Noble *et al.*, 1996). Ambient sampling, provides information about the concentration of a chemical for a site at a point in time. This method of monitoring will only provide limited data for the calculation of total loads delivered from a catchment to the coast.

In response, the Coastal CRC initiated a monitoring program in 2001 (as a part of a larger research effort) to quantify the concentration and load of pesticides delivered to the Fitzroy estuary from the catchment. The methods used for water sampling and some of the findings of the flood monitoring are given below in Section 5.2. Spot sampling methods, while indicating the load of pesticides entering the estuary, do not, however, provide insights into the incorporation of the pesticides into the estuarine biota. Consequently we conducted a preliminary investigation into the levels of persistent organic pollutants in saltwater crocodile eggs. This commenced in 2002. Crocodiles are at the top of the food chain and represent an end-point for bioaccumulation. These contaminants can then be passed on maternally to developing young (eggs). The methods and interim results for this survey are given below in Section 5.3. The survey was constrained in the number of eggs and locations which could be sampled and readers are reminded that the results should be taken as indicative rather than definitive.

### 5.2 Pesticides in floodwater from the Fitzroy catchment for the years 2002 and 2003

In the summer of 2002 and 2003 a timed-series of manual plunge samples of floodwater, flowing through the Fitzroy River barrage at Rockhampton, were collected and analysed for a number of common pesticides. Flow data from an upstream gauging station were corrected for time-of-travel to Rockhampton and used to calculate total-flood loads of chemicals based on the concentration of pesticide in

the water sample. The most frequently detected pesticides at a concentration of concern in the water samples were Atrazine, Diuron and Tebuthiuron (Table 12). Atrazine and Diuron are pre-emergent herbicides and are mainly used to control weed growth in crops by spraying a mixture of the chemicals onto cultivated soils. Tebuthiuron is used to control woody weeds (trees) and can be applied via spraying (liquid) or pellets. Other chemicals detected less frequently and at a lower concentration (not reported here) were Simazine, Hexazinone, Prometryn, Fluometuron, Ametryn, Dieldrin, Chlorpyrifos and the degradation products of Atrazine (Desethyl atrazine and Deisopropyl atrazine).

Table 12. A summary of the concentration ( $\mu\text{g/L}$ ) and load (kg) of Atrazine, Diuron and Tebuthiuron delivered to the Fitzroy estuary during 2002 and 2003 floods, where ML = mega litres or millions of litres and  $\mu\text{g/L}$  = micrograms per litre.

Sampling site and year of flood	Flow volume	Number of samples	Atrazine			Diuron			Tebuthiuron		
			Max	Mean	Total load	Max	Mean	Total load	Max	Mean	Total load
			( $\mu\text{g/L}$ )	( $\mu\text{g/L}$ )	(kg)	( $\mu\text{g/L}$ )	( $\mu\text{g/L}$ )	(kg)	( $\mu\text{g/L}$ )	( $\mu\text{g/L}$ )	(kg)
Fitzroy River (estuary) 2002	295000	5	2.100	0.36	106	0.200	0.044	13	0.480	0.24	70
Fitzroy River (estuary) 2003	1758000	8	0.060	0.04	65	0.060	0.005	8	0.140	0.07	117

The ANZECC (2000) guideline (default trigger) values do not include concentrations for a number of the pesticides detected in water samples of the Fitzroy estuary. There are also no 99% ecosystem protection values for Diuron in fresh or marine waters and none for Atrazine and Tebuthiuron in marine waters due to a lack of data to determine values. Maximum and mean concentrations for some chemicals exceeded the ANZECC (2000) water quality guideline values for both 95 and 99% ecosystem protection (Table 13).

Maximum Atrazine concentrations exceeded the 99% ecosystem protection values for the 2002 flood for freshwater systems. Maximum Diuron concentrations were equal to or exceeded the 95% ecosystem protection values for freshwater systems for the 2002 flood. Maximum and mean Tebuthiuron concentrations exceeded the 99% ecosystem protection values for freshwater systems for the 2002 and 2003 floods

Higher maximum (and mean) concentrations of pesticides were observed for the 2002 flood when compared to the maximum concentrations for the 2003 flood. This may be due to the source of the floodwater and antecedent conditions leading up to this smaller flood. The 2002 flood originated from an intense localised storm over an area (about 650 km upstream of Rockhampton) where land use is mainly intensive cropping with some grazing on less productive country. The storm occurred not long after (within a few weeks) applications of pesticides and there was some localized severe erosion. In comparison the 2003 flood originated from widespread rain falling on a far larger area where grazing was the dominant land use. The 2003 flood originated much closer to the coast (100 to 300 km upstream of Rockhampton) and both floods occurred during very dry (drought) periods. Therefore, the differences in pesticide concentrations may be attributed to land use, chemical application and rain intensity.

Table 13. The ANZECC (2000) default trigger values for tropical Queensland for Atrazine, Diuron and Tebuthiuron concentrations in micrograms per litre ( $\mu\text{g/L}$ ), where ID = Insufficient Data to determine a trigger value.

ANZECC (2000) Water Quality default targets for tropical Queensland	Ecosystem protection value	Upland River	Lowland River	Estuary	Inshore
Atrazine ( $\mu\text{g/L}$ )	95%	13.00	13.00	13.00	13.00
	99%	0.70	0.70	ID	ID
Diuron ( $\mu\text{g/L}$ )	95%	0.20	0.20	1.80	1.80
	99%	ID	ID	ID	ID
Tebuthiuron ( $\mu\text{g/L}$ )	95%	2.20	2.20	2.20	2.20
	99%	0.02	0.02	ID	ID

Recent research on the effects of Atrazine and Diuron have shown that both chemicals can have substantial impacts on seagrasses and corals at concentrations similar to those found in the 2002 and 2003 floodwater reaching the Fitzroy estuary (Haynes *et al.*, 2000b; Jones *et al.*, 2003). It is of concern that Tebuthiuron (highly toxic to woody plants) was found at these concentrations in floodwater delivered to the Fitzroy estuary. This would indicate that the chemical is perhaps more mobile than previously thought. The delivery of this type of chemical to coastal waters could affect mangroves and other communities. The monitoring of floodwater from the catchment to the estuary will continue in collaboration between the Coastal CRC, the National Action Plan for Salinity and Water Quality, and the Department of Natural Resources and Mines.

### 5.3 Persistent organic pollutants in eggs of the saltwater crocodile from the Fitzroy river (a preliminary investigation)

The saltwater crocodile (*Crocodylus porosus*) is at the top of the food chain in the Fitzroy River system. The Fitzroy region is recognised as the southern breeding limit for the saltwater crocodile. A preliminary survey was conducted to compare the availability and bioaccumulation of persistent organic pollutants in several Australian coastal ecosystems including the Fitzroy River system.

Non-viable eggs of the saltwater crocodile were collected from three sites across the tropics of Northern Australia and analysed for persistent organic pollutants over the 2002 and 2003 summer breeding seasons. DDE (a metabolite of DDT) was found to be the most prevalent pollutant for all sites. All eggs analysed (from all sites) had detectable residues of DDE, though slightly more than half the samples (12 of 21) had only minimal amounts (less than 10 ppb). A number of eggs were also contaminated by other persistent pollutants at trace levels including Polychlorinated Biphenyls (PCB) congeners. The mean concentration of DDE in eggs from the lower Fitzroy River system was about four times the mean concentration detected in eggs from the Adelaide (Northern Territory) and Proserpine (Northern-Central Queensland) rivers (Fig. 19).

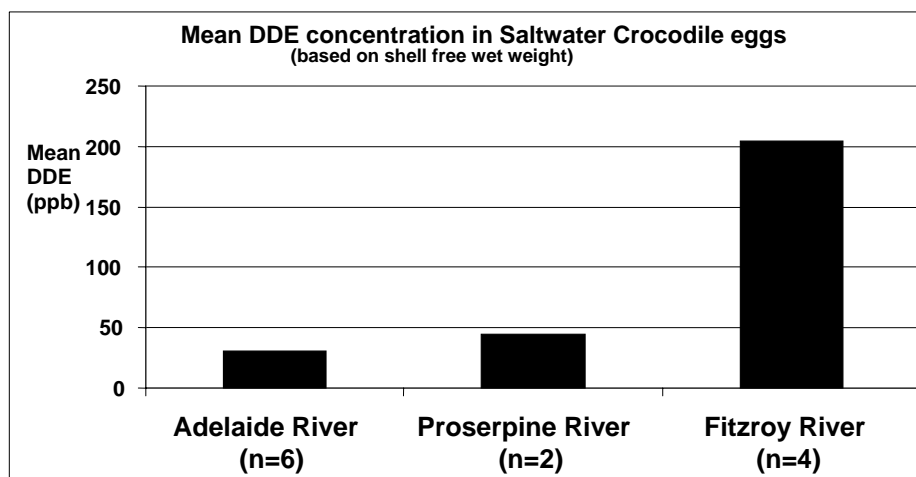

**Figure 19.** Mean DDE concentrations in the eggs of the saltwater crocodile (*Crocodylus porosus*) from the Adelaide (Northern Territory), Proserpine (North-Central Queensland) and Fitzroy Rivers (Central Queensland) in parts per billion (ppb), where n = number of eggs analysed for persistent organic pollutants.

The parent chemical DDT is thought to have been used extensively in intensive agriculture in the Fitzroy catchment in the past to control insect pests (with its use declining rapidly from the 1970s onwards). Historically, the use of DDT in the Adelaide and Proserpine catchments is not as well known, however, it is probable that both catchments had far lower DDT applications. This is mainly because the Adelaide River catchment has had very limited intensive agriculture in the past and the area of intensive agriculture in the Proserpine region does not form part of the main catchment. Cattle grazing is the dominant land use for all three catchments. The drainage area of the Fitzroy, Adelaide and Proserpine catchments are 142,600, 4,400 and 550 km<sup>2</sup>, respectively.

Another potential source of DDE is through aerial transport from distant sources of DDT and DDE. Aerial deposition of DDT (and DDE) occurs globally (Kalantzi *et al.*, 2001; Smith, 1999), and the observed DDE concentrations reflect both global and purely local applications. The higher concentration for the Fitzroy catchment eggs may be due to more extensive historical use. Or, the much larger surface area of the Fitzroy (compared to the two smaller catchments) could lead to a greater concentration of aerial deposition of DDT (and therefore DDE) in the river system.

The maximum concentration of DDE found in eggs from the Fitzroy River system was 350 ppb (two eggs from one nest). This work compliments similar recent studies for the Central American region where comparable concentrations were detected in crocodilian eggs. The results of studies into DDE contamination of crocodilian eggs in Central America suggest that at these concentrations (350 ppb) there may be limited impact on crocodilian health (Wu *et al.*, 2000). There may be cause for concern, however, in relation to subtle sub-lethal effects (for example breeding success). The results of this preliminary survey provide new information for wild crocodile management issues concerned with toxicology. It shows how the species is

a valuable long-term indicator of ecosystem health and contaminant exposure. A more detailed report of the findings of this study can be found in a poster paper delivered to the 17th Working Meeting of the Crocodile Specialist Group, IUCN, Darwin, May, 2004 (Packett *et al.*, 2004).

## CHAPTER 6. SOURCES OF SEDIMENT TO THE FITZROY ESTUARY

### 6.1. Introduction

One of the strong stakeholder concerns reflected in the development of the work plan for this Project was the identification of the principal sources of sediment entering the Fitzroy estuary. This concern arises from the desire to reduce the deliveries of sediments and particulate-attached nutrients to the Great Barrier Reef (GBR) lagoon. Since the project started, these concerns have been given greater urgency through government decisions to mandate major reductions in sediments and nutrients from many of the catchments (including the Fitzroy) draining eastward into the GBR, and to apply considerable funding under the National Action Plan for Water Quality and Salinity (NAPSWQ) to measures aimed at reducing sediment and nutrient deliveries. Given the size of the Fitzroy catchment and the logistic difficulties, an on-the-ground assessment of all potential sediment sources is not feasible. This is quite apart from the complexities of nature (i.e. highly episodic rainfall varying in location and intensity falling on soils of widely varying erodibility).

We have adopted here a geochemical approach to identifying and quantifying sediment sources. Essentially, this involves measuring the geochemical characteristics of sediment samples from the estuary, as well as a comparable suite of representative samples from the catchment. We then use a variety of statistical techniques and a purpose-built mixing model to compare the geochemistries of the estuary and catchment samples, and identify where the closest matches occur between the two sample sets. This technique has the capacity to construct theoretical mixtures derived from different parts of the catchment to produce an optimal fit to the samples from the estuary. Since the estuary receives inputs from all parts of the catchment, the sediments there are, of necessity, a mixture (of initially unknown proportions) of all the possible sediment sources. This methodology has proved effective when applied to sediment sourcing problems in smaller catchments elsewhere in Queensland. This is, however, the first time this methodology has been applied to a catchment as large as the Fitzroy with such a complex geology. Figure 24 at the end of this chapter shows the geological provinces and the major rivers in the Fitzroy catchment.

In the past year there has been a major effort to apply an alternative approach to sediment sourcing which is quite different from the geochemical one we have pursued. This other method applies mathematical models (such as SedNet) to quantify sediment generation and transport on a sub-catchment scale and then integrates across the whole catchment to get an end-of-catchment estimate of sediment delivery, as well as identification of the potentially largest sediment sources at the sub-catchment scale. These modelling techniques rely on various empirical relationships such as the Universal Soil Loss Equation to relate sediment delivery to catchment characteristics at a sub-catchment scale, and to quantifying sediment transport through the network of streams linking the sub-catchments to the sea. In addition, various model parameters are 'tuned' to achieve a good concordance between the modelled and measured sediment deliveries at the end of catchment. Although the geochemical data from the Fitzroy catchment and estuary reported here has been collected to meet our project objectives, this geochemically-based empirical approach has great potential



value for improving the accuracy and realism of the mathematical modelling approach by providing geochemical constraints on the material being delivered to the estuary. This should be regarded as a high priority task for future work.

## 6.2. Sampling strategies, and major and trace element analysis

### 6.2.1 Estuary

Samples were collected from 70 different subtidal locations (Fig. 20) near the mouth, and in the Fitzroy estuary proper, using an Eckman grab. The sediment samples were size fractionated using standard techniques and the finest particles ( $< 10 \mu\text{m}$ ) which formed the major component of most samples were used as the estuarine samples.



**Figure 20.** Sample site locations for collection of Fitzroy estuarine sediments, December 2001.

### 6.2.2 Fitzroy catchment

One hundred and three surface samples were collected at specific locations in the Fitzroy catchment. The sample sites were chosen to characterise as many of the different rock types as possible (and hence derivative soils types produced during weathering) in the catchment. As with the estuarine sediments, the soil samples were size fractionated and the finest particles ( $< 10 \mu\text{m}$ ) were used as the soil samples.

### 6.2.3 Dams, weirs and flood samples

Sediment samples were collected using an Eckman grab from Gyranda, Glebe, and Theodore weirs (on the Dawson River); Comet weir which is at the end of the Comet River just before it joins the Nogoia River to form the Mackenzie River; Bedford, Bingegang, and Tartus weirs (all on the Mackenzie River) the Theresa Creek Dam near Clermont (in the north west of the Fitzroy catchment), and Fairbairn Dam on the Nogoia River (upstream of Emerald). With the help of NR&M staff samples were collected during a flood from the Comet catchment at the Comet, Bedford and Bingegang weirs. In addition, flood samples were collected at the Fitzroy Motor Boat Club in Rockhampton. All sediment samples were size fractionated to produce the  $< 10 \mu\text{m}$  samples. The flood material was isolated by chemical flocculation and not size fractionated. Electron microscopy indicated that the vast bulk of the flood particles

were < 10 µm in diameter. The locations of the various weirs together with the major geological provinces are shown in Figure 21 (below).

#### 6.2.4 Major and trace element analyses

The < 10 µm fraction of sediment and catchment soil samples were analysed by CSIRO using X-ray fluorescence (XRF) for major (SiO<sub>2</sub>, Al<sub>2</sub>O<sub>3</sub>, Fe<sub>2</sub>O<sub>3</sub>, MnO, MgO, CaO, Na<sub>2</sub>O, K<sub>2</sub>O, TiO<sub>2</sub>, P<sub>2</sub>O<sub>5</sub>) and trace elements (Ba, Ce, Cl, Cr, Co, Cu, Ga, La, Ni, Nb, Pb, Rb, S, Sr, V, Y, Zn, Zr). Neutron activation analysis (NAA) by Becquerel Laboratories, Australia, was used for major (Ca, Fe, Na and K) and trace elements (Ag, As, Au, Ba, Br, Ce, Co, Cr, Cs, Eu, Hf, Ir, La, Lu, Mo, Nd, Rb, Sb, Sc, Se, Sm, Ta, Tb, Te, Th, U, W, Yb, Zn, Zr). (We have used, here and in the rest of this chapter, the standard abbreviations (Cotton and Wilkinson, 1962) for the different chemical elements and the compounds we analysed for.)

### 6.3 Results and discussion

#### 6.3.1 Estuary sediments

For the samples collected in December 2001, the estuarine sediments are derived predominantly from Thomson Fold Belt (TFB) and New England Fold Belt (NEFB) soils (approx. 30% each), while Bowen Basin (BB) and Surat Basin (SB) soils make up the rest, with a small (~10%) contribution of Tertiary Basalt (TB) soils. Readers should keep in mind that the estuarine sample composition reflects sediment inputs by repeated earlier flood events. They may not be, however, totally representative of the total long term input. There is considerable longitudinal variation in the proportions of the BB and SB components along the estuary reflecting variations in the mineralogy of the sediments derived from the different geological provinces. However, relative to the disparities between the extremes of the combined dataset of the estuarine sediments, catchment soils, dam and weir samples, and the flood samples, the estuary samples form a very tight knit group. This is seen (Fig. 21) where plots of La versus Th show the dominance of sedimentary sources (TFB, SB, BB and NEFB). The greater dispersion of weir and dam samples reflects the fact that not all soil types are present in each sub-catchment, resulting in greater relative geochemical variation.

Laboratory experiments using sediments isolated from upstream freshwater and then immersed in seawater, show that the chemical composition of some of the sediments is rapidly altered by the transition from freshwater to saltwater which occurs when the sediments enter the estuary. This result has the potential to introduce confounding effects into the geochemical interpretation. Note also that an implicit assumption in the geochemical approach is that there has been no fractionation of the entering material within the estuary, i.e. the estuarine sediments are a representative sample of the material delivered from the catchment.

#### 6.3.2 Catchment soils

As can be seen from Figure 21, and the plots of K<sub>2</sub>O versus TiO<sub>2</sub> in Figure 22, the soils derived from the various major geological provinces can be differentiated from each other. Especially clear-cut are the differences from the TB (Tertiary Basalt) which is an important component the northern Nogoia and Comet catchments of the Fitzroy Basin.

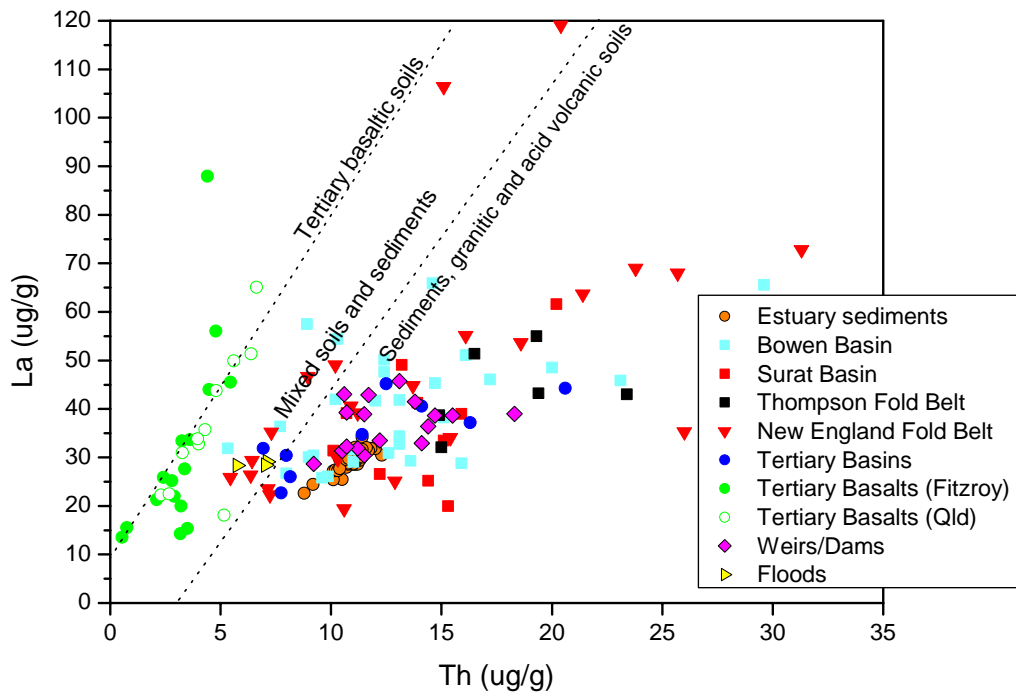

**Figure 21.** Concentrations ( $\mu\text{g/g}$ ) of La versus Th for Fitzroy River Estuary sediments, Fitzroy River Basin soils, weir, dam sediments and flood event sediments.

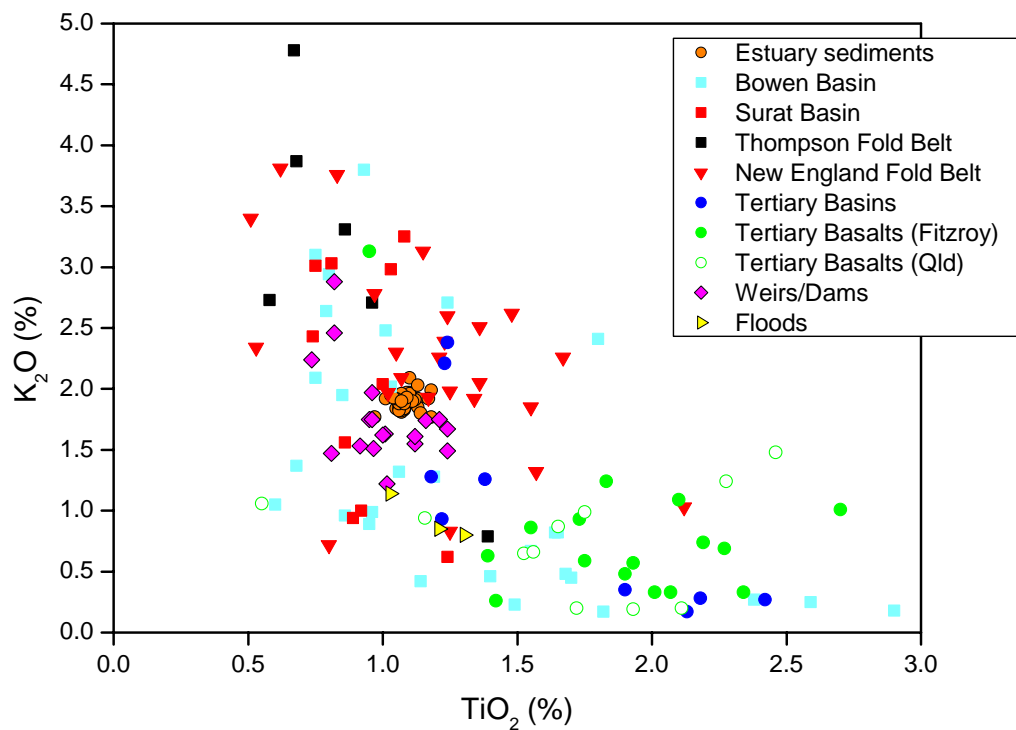

**Figure 22.** Concentrations (%) of  $\text{K}_2\text{O}$  versus  $\text{TiO}_2$  for Fitzroy River Estuary sediments, Fitzroy River Basin soils, weir, dam sediments and flood event sediments. Tertiary Basalts (Qld) are from the Moreton Bay catchment, SE Queensland.

From the major and trace element geochemical analyses of the Fitzroy estuary sediments and catchment soils we can use a sophisticated mathematical technique (Douglas *et al.*, 2004) to ‘sort’ all the soil samples into a small number of different groups. Each group corresponds to a major geological zone initially identified and referred to as ‘endmembers’. The technique ensures that the members (soil samples) of each endmember differ between themselves less than they differ from the members of any other group. The estuary samples can then be compared to the various endmembers. The results shows that the sediments from the Fitzroy estuary vary little relative to the Fitzroy catchment soils and are mostly contained within the field defined by three endmembers; the sedimentary/granitic soils of the TFB, the sedimentary soils of the SB and BB and the TB soils (Fig. 21). There are 5 catchment soil endmembers for the whole of the Fitzroy catchment (Bowen Basin – BB, New England Fold Belt – NEFB, Surat Basin – SB, Tertiary Basalts – TB and Thomson Fold Belt – TFB). A summary of model estimates of the proportions of these five catchment endmember soil types retained in the FRE are presented in Table 14.

Table 14. Modelled estimates of the percentage of catchment soil endmembers in the Fitzroy River Estuary.

<b>Catchment Endmember</b>	<b>Bowen Basin</b>	<b>New England Fold Belt</b>	<b>Surat Basin</b>	<b>Tertiary Basalt</b>	<b>Thomson Fold Belt</b>
Estuary Abundance <sup>(1)</sup>	22 ± 13	23 ± 14	15 ± 10	10 ± 5	30 ± 7
Catchment Abundance <sup>(2)</sup>	46.0%	19.0%	18.6%	9.5%	6.9%
Enrichment Factor	0.5	1.2	0.8	1.1	4.3

(1) estimated  $\mu \pm 1 \sigma$  calculated using the Bayesian mixing model

(2) relative abundance calculated in absence of Duaringa and Biloela Basins (see Fig. 24).

#### 6.4. Summary and conclusions

While all the different geochemical provinces of the Fitzroy Basin contribute to sediment delivered to the estuary, the Thomson Fold Belt in the most north-western part of the catchment appears to be a disproportionately large contributor relative to its area in the catchment. The TB soils, common in the Nogoia and Comet catchments are the next most disproportionate contributor to estuarine sediments. These results suggest that these two regions are the strongest sources of sediments delivered to the estuary. Consequently, they should be the greatest focus to more precisely define the source areas (or identify particular management practices widespread in these regions which lead to major sediment transport). Examination of the limited number of flood events during this study suggests that for those floods arising from the Comet, Nogoia, Mackenzie and Dawson catchments a significant proportion of the sediment is of basaltic origin. We noted that the phosphorus content of the Fitzroy Basin Tertiary Basalts was not disproportionately high relative to the other rock types. This is different from other Queensland catchments where the Basaltic material is phosphorus enriched.

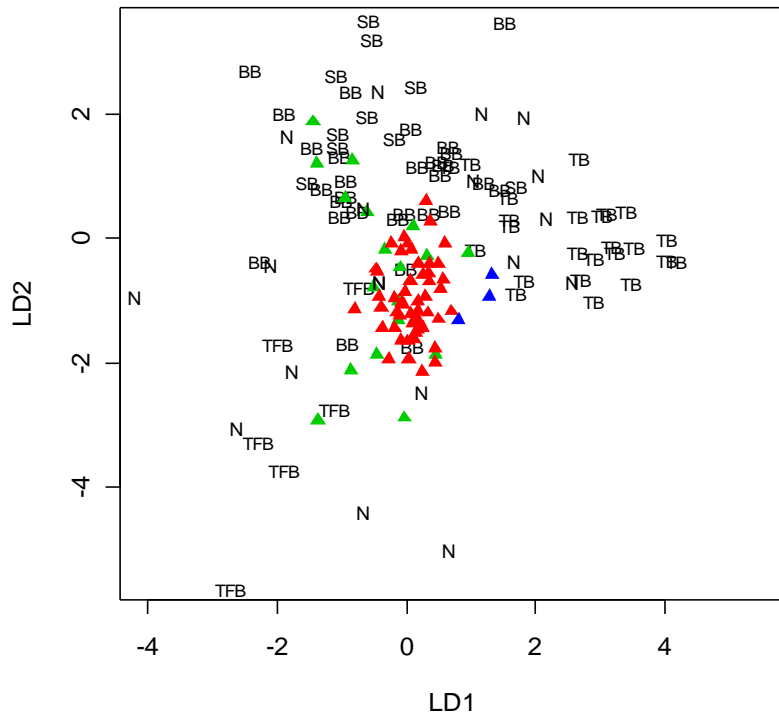

**Figure 23.** Canonical variate scores for selected Fitzroy Basin catchment soils, Fitzroy estuary, weir and dam and flood sediments (TFB – Thomson Fold Belt, SB – Surat Basin, BB – Bowen Basin, N – New England Fold Belt, TB – Tertiary Basalts, red triangle – Fitzroy estuary sediments, green triangle – weir sediments, blue triangles – flood sediments).

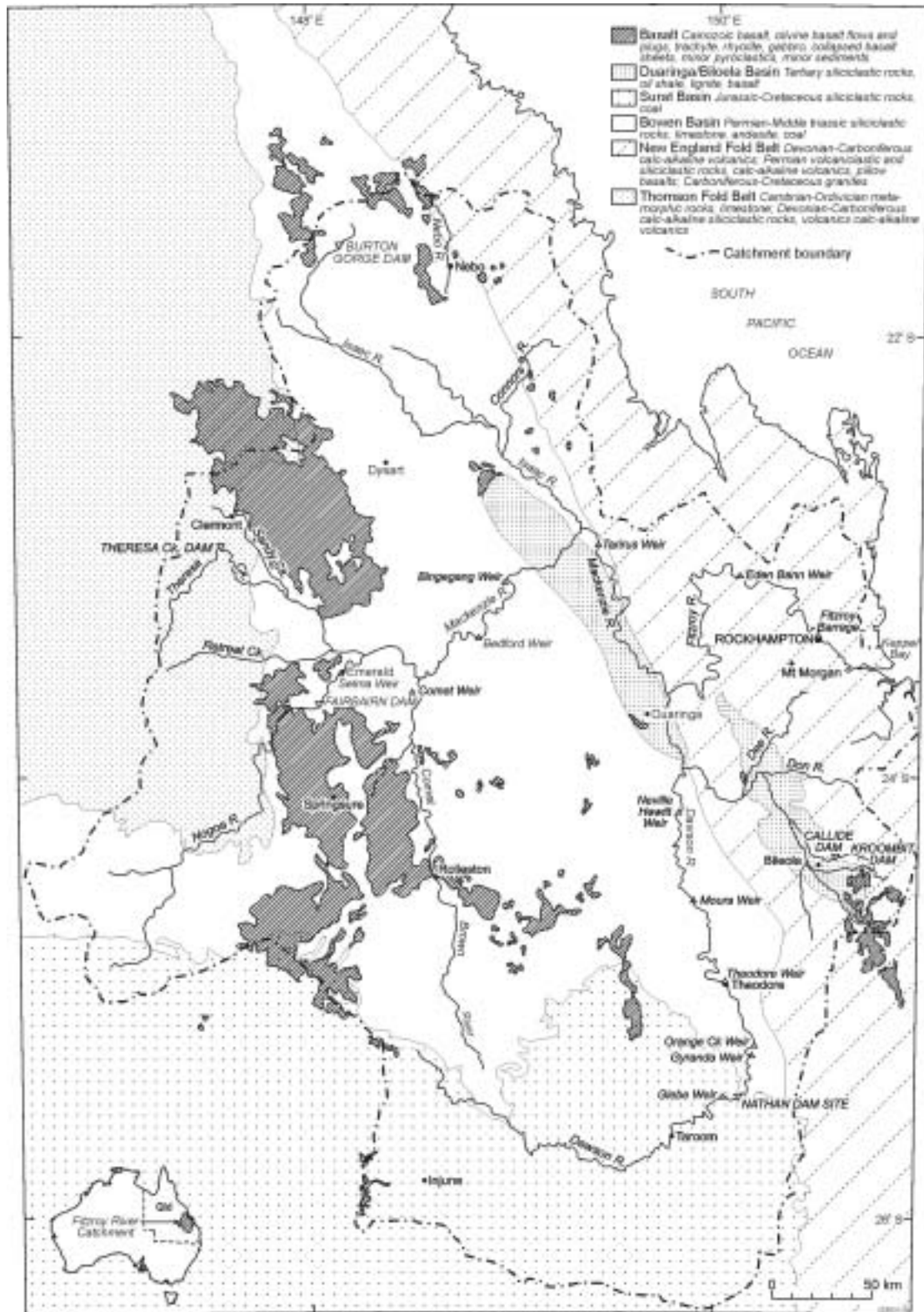

**Figure 24.** Locations of dam and weir sites, and major rivers, together with principal geological provinces in the Fitzroy catchment.

# CHAPTER 7. SEDIMENT DELIVERY AND SEDIMENT DYNAMICS

## 7.1 Introduction

As noted in Chapter 1, one of the factors motivating the work of this project has been stakeholder concerns over the quantities and fates of the large loads of sediment delivered to the Fitzroy estuary by flood events. In earlier chapters (especially chapter 4) our focus has been on the particles as vectors for transporting nutrients bound to their surfaces (i.e. Particulate Organic Nitrogen, Particle Organic Phosphorus, etc), and as controls on the available light within the water column. By modulating the available light the particle load controls primary production in the water column. In this chapter we look at the processes within the estuary which control the abundance and distribution of sediments delivered to the estuary by flood waters. The flood sediments delivered are generally very fine clay particles (mean diameter  $\sim 1 \mu\text{m}$ ). From work in other systems, it is reasonable to expect that these particles, when exposed to salt water would flocculate (clump together) to form much larger particles which will settle more rapidly than the fine particles. The settling of the particle aggregates will be countered by the turbulence in the water generated by the macrotidal flows. These effects mix the estuary vertically as well as resuspending already settled particles. The intense tidal mixing is the reason why only very slight differences in oxygen content, salinity, and temperature are observed between the top and bottom of the water column. These same tidal forces can disaggregate (break up) the aggregated particles, producing many smaller, and more slowly settling, particles. There is thus a dynamic interplay between the flocculation processes, contributing to more rapid particle removal from the water column, and tidal resuspension and disaggregation reintroducing settled material into the water column and producing smaller particles which will remain in the water column longer. These processes go on over a variety of space and time scales and are particularly dependent on location and time since the last flood. In this chapter we summarize the work of the project exploring these issues.

## 7.2 Flocculation and aggregation

Simple settling experiments were conducted by mixing freshwater laden with sediments (collected upstream of the barrage during the minor inflow of March 2003) with varying amounts of seawater. These suspensions were allowed to stand (8 hours), and before the suspended sediment remaining in the top 80% of the column was removed and measured. The results (Fig. 25) show firstly, that the incoming particles are highly sensitive to low concentrations of seawater (salinity of 1‰ corresponds to about 3% seawater). More than 90% of total sediment load settled out within 8 hours in the freshwater with a slight addition of seawater. In freshwater alone, this degree of settling by unflocculated particles would require at least several weeks to achieve the same degree of particle removal. Secondly, the effects are greatest at very low additions of seawater to the freshwater. As can be seen from Figure 25, doubling the salinity from 1‰ to 2‰ produces no additional aggregation and settling. In contrast, an increase from 0.5‰ to 1‰ will produce a 50% increase in the amount of material settling out in the short time span of the experiment. Clearly, the effectiveness of this settling process depends on the surface chemistry of the particles. The sediment tracing work (Chapter 6) shows that the soils of different Fitzroy sub-catchments have different mineralogies, and thus different surface chemistries. Consequently, it is

likely floods from different regions of the catchment will deliver particles with different sensitivities to seawater and thus different settling characteristics.

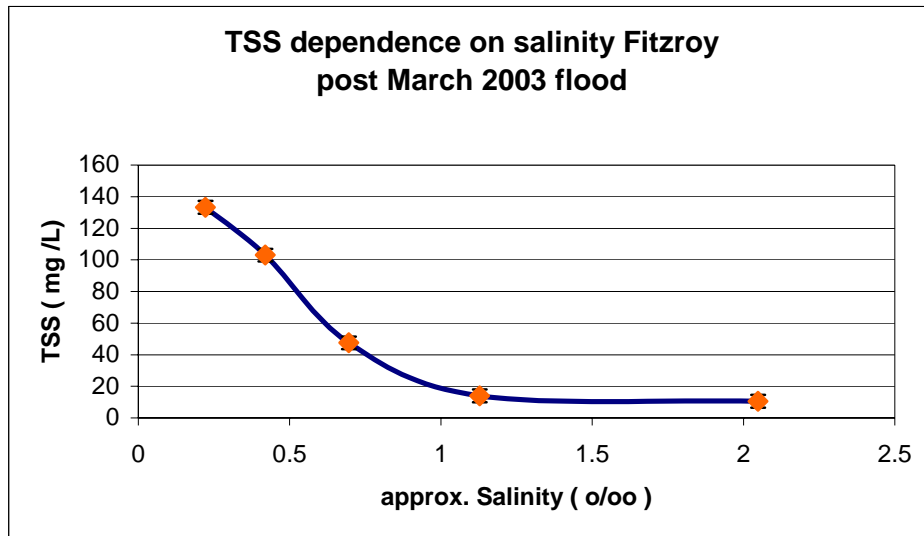

**Figure 25.** Residual suspended sediment concentration (after 8 hours) in freshwater from Fitzroy River (post March 2003 flood) with minor additions of seawater.

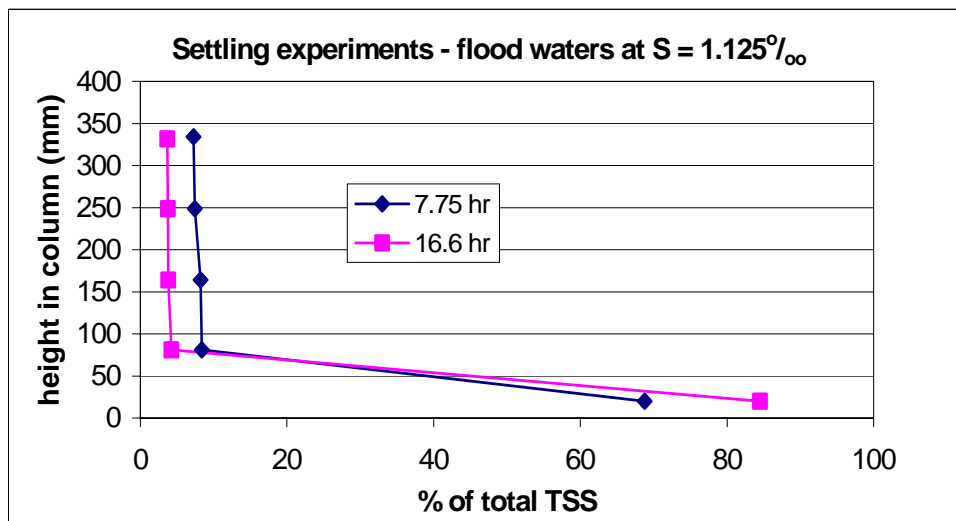

**Figure 26.** Column settling experiments. Suspended material concentrations at five different depths in separate columns at two times (7.75 hr and 16.6 hr) after addition of seawater to Fitzroy River water to raise the salinity to 1.125‰.

Column settling experiments (Fig. 26), were carried out by mixing Fitzroy River water with small amounts of sea water to raise the salinity to  $S = 1.125‰$ . The concentration of sediment remaining at different depths in the water column was then measured. The results show that most of the particles have settled out within 7.75 hours of the start of the experiment, and that only a additional 5% settle in a further 8.85 hours. Furthermore, the concentrations of particles remaining in suspension are constant with depth (except for the bottom sample (75 mm) which includes material which has settled out already). These results indicate that the particle aggregation



does not involve all the particles simultaneously. The most convincing explanation of the observations, which is consistent with extant theory, is that aggregation is a process where positive feedback operates. Once two particles have aggregated the new larger particle will settle faster. As it does so it 'bumps' into more particles which are, in turn, incorporated into the bigger settling particle producing even faster settling. Thus, at any time, the column contents consist of unaggregated particles uniformly distributed throughout the column, and aggregated particles settling rapidly to the bottom. As the initiation of the aggregation depends on the collision of two small particles, the process slows down as more and more fine particles are removed from the system. The lower the particle concentration, the lower the rate of collision, and the lower the instantaneous rate of aggregation.

This analysis has important implications for understanding the behaviour of freshwater floods, especially the fine suspended sediments they contain, once the flood waters enter Keppel Bay, and interact with seawater there. Initially, a salt wedge will form with the particle-laden freshwater overlying the denser seawater. Mixing across the interface between them will increase the salinity of the freshwater layer, slightly at first, leading to rapid aggregation and rapid settling out of much of the suspended material close to the mouth of the estuary. Increasing mixing of saltwater into the freshwater layer, once the critical salinity has been reached (this appears to be about 1‰), does not produce further aggregation, so a surface plume of sediment-depleted increasingly salty water is displaced from the mouth of the estuary into Keppel Bay by the continuing inflow of freshwater. Particle loss from this expanding plume continues at an ever-decreasing rate as the particle concentration within the plume declines. Macrotidal turbulence can return some of the flocculated material to the upper layer, but this material soon settles out again. Because the surface flood plume still contains mainly unaggregated fine particles, which are mainly responsible for light adsorption and scattering, the plume still appears relatively optically dense (interpreted as being sediment-laden), though TSS concentrations have been substantially reduced compared to the entering plume. This phenomena has the potential to cause difficulties when deriving sediment flux measurements using remote sensing techniques.

### **7.3 Sediment transport dynamics**

The factors controlling sediment dynamics in the Fitzroy have been reviewed in detail in the Coastal CRC's numerical modelling work done in association with this project and reported in Margvelashvili *et al.* (2003). The mathematical model which quantifies sediment transport was calibrated from the monthly field measurements made in this project so the conclusions are highly relevant and cover, in part, the same ground. To provide the reader with a coherent overview of all the relevant processes involved in the transport of particulate carbon and nutrients, as well as sediments, we set out below a brief summary of the major conclusions of the numerical modelling report. We then describe some experimental results from our work which illustrate (and confirm the conclusions drawn from the numerical models). Conditions under low and high flows are quite different and we set these out separately below:

#### **a. Low flows**

- Sediment transport is driven by tidal flows: the Fitzroy is a macrotidal system with large tides (> 5m) and high tidal velocities.
- Tides are semi-diurnal and vary markedly over a spring-neap cycle every month. Sediment resuspension and transport depends on exceeding a

critical shear velocity, and the local velocity depends on the local cross-sectional area and position in the estuary. Consequentially, sediment resuspension and deposition varies spatially over scales from metres to kilometres, and temporally over tidal cycles (hours), spring-neaps (months), and annually.

- Tidal velocities (and thus resuspension rates) are greatest near the mouth and least at the head of the estuary. Consequently, turbidity and suspended sediment concentrations are highest at the mouth and lowest at the head of the estuary (once salt water has penetrated far enough upstream to raise the salinity level sufficiently to cause flocculation).
- Because of the tidal asymmetry, i.e. tidal inflows are shorter duration than tidal outflows, tidal inflow velocities are higher than tidal outflow velocities. Consequently, fine sediment is pumped up the estuary. Fine sediment deposition occurs mainly in the upper estuary while coarser sediments accumulate closer to the mouth. Especially high deposition of fine sediment near/in the ‘Cut-through’ is predicted.

b. High flows

- Under high flow conditions there is a net discharge of sediment to the Keppel Bay. This material consists of fresh sediment coming from the catchment plus remobilized sediment from the estuary. The transport of material out of the estuary persists only during the inflow event. On an annual scale, the modelling results suggest that much of this exported sediment material is returned and retained within the estuary.

### **7.3 Experimental observations**

The monthly surface sampling program collected surface water samples at 13 locations along the estuary, and measured vertical profiles of physical properties through the water column at each sampling site. A frequent observation was that the turbidity increased with depth, as well as generally increasing down estuary. While the downstream increase in surface turbidity was consistent with the model, the vertical variation could not be predicted as the model was, essentially, only a 2D model. We made more detailed and repeated investigations of the suspended solids concentration (Total Suspended Solids = TSS) at several stations along the estuary over the tidal cycle. These measurements were made in conjunction with an ADCP (Acoustic Doppler Current Profiler) instrument which measures water velocity simultaneously at various depths in the water column. In principle, it is also possible with this instrument to infer the sediment concentration at the same points using the intensity of the back-scattered acoustic signal. This assumes that the particle size and composition is unchanging. Unfortunately this wasn't the case during the Fitzroy experiments and TSS concentrations were measured from discrete samples retrieved at the different depths using a 5 litre Niskin bottle. Figure 27 shows the variation of TSS with depth at 4 different stations along the estuary. Apart from a single surface measurement at Rocky Point (at the turn of the tide when there was rapid particle settling), the results conform to the anticipated pattern of TSS higher downstream and lower upstream. While relatively uniform with depth at the 3 sites of decreased tidal forcing, there is a strong variation of TSS with depth at the deepest and most downstream site (Rocky Point) consistent with resuspension of material from the bottom. More detailed observations at selected upstream and downstream sites – Nerimbera (approx. 15 km downstream of the barrage) and Thompson's Point (15 km

from the estuary mouth) showed (Fig. 28) showed more complex behaviour with virtually uniform TSS concentrations at Nerimbera during the ebb phase (before 14:00) of the tide, but marked vertical gradient during the flooding phase (after 14:00). Although the surface concentration remained virtually unchanged the bottom concentration increased by a factor of 6 during the inflow event. This increase can be due to either advection of resuspended material from downstream, or resuspension of fine sediments in the immediate area. Either way, the results show how the tidal asymmetry with faster up-estuary transport of fine sediments on the flood tide, as opposed to the slower ebb tide, leads to net upstream transport of sediments.

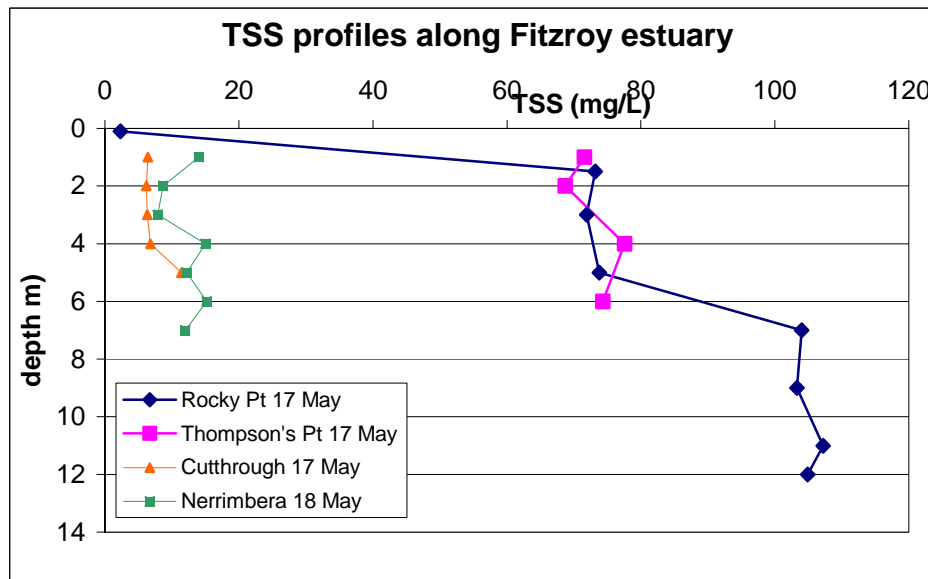

**Figure 27.** Variation of TSS concentration (mg/L) with depth and along length of Fitzroy estuary over part of the tidal cycle. Upstream: Nerimbera and Cut-Through; and downstream: Thompson's Point and Rocky point.

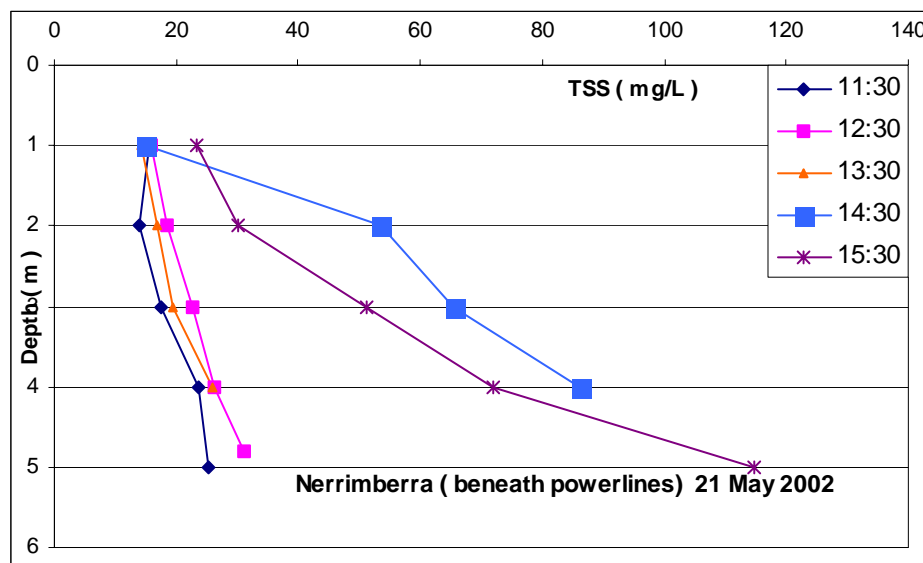

**Figure 28.** Variation of TSS concentration (mg/L) over part of the tidal cycle at Nerimbera (Upstream site). The tide was ebbing until approximately 14:00 and flooding thereafter.

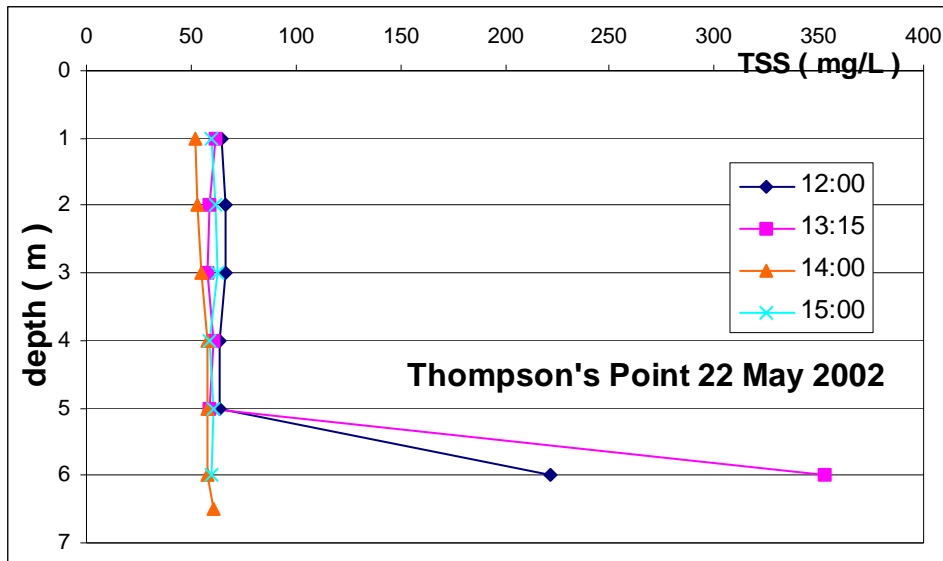

**Figure 29.** Variation of TSS concentration (mg/L) over part of a tidal cycle at Thompson's Point. Flooding tide until 13:30 and ebbing tide thereafter.

The vertical profile of sediment concentration at Thompson's Point (Fig. 29) where the tidal velocities are much higher, shows quite dissimilar behaviour from the upstream site, with the sediment concentration remaining constant with depth throughout most of the tidal cycle. Major increases in the sediment concentration only occur at the deepest sample point and at the time of higher velocity. Examination of the material collected on these 2 occasions shows that it consists of a mixture of the fine sediment usually collected, together with sand grains. This result indicates that the bottom velocities, in part of the tidal cycle at these downstream sites, are sufficient to cause saltation (bouncing of sand particles along the bottom). This movement will not be captured by surface observations, nor by the use of optical instruments deployed at depth. These deficiencies highlight the need for detailed sampling at the downstream end of the estuary to get an accurate indication of the amount of material actually delivered into Keppel Bay.

It may be asked where is the source of the material being transported into the Fitzroy estuary by the asymmetric tides. A reanalysis of the very extensive data set gathered in Keppel Bay by Brodie and Mitchell (1993) immediately after the 1991 flood. The analysis suggests that there is rapid removal of sediment in the low salinity zone immediately in front of the Fitzroy mouth. This is consistent with results in other systems such as the Amazon (Milliman *et al.*, 1975). The results (taken together with the modelling work) reported here suggest that much of this material is subsequently re-injected into the estuary rather than being transported further seaward or northwards along the coast.

## REFERENCES

- Australian and New Zealand Environment and Conservation Council and Agriculture and Resource Management Council of Australia and New Zealand (ANZECC and ARMCANZ) (2000). *Australian and New Zealand Guidelines for Fresh and Marine Water Quality. Volume 1. The Guidelines; Volume 2. Aquatic ecosystems; Volume 3. Primary Industries*, ANZECC and ARMCANZ. <http://www.ea.gov.au/water/quality/nwqms/index.html#quality>
- Brodie, J. and A.R. Mitchell (1993). *Nutrient composition of the January (1991) Fitzroy Flood plume*.
- Brodie, J., L.A. McKergow, I. P. Prosser, M. Furnas, A.O. Hughes and H. Hunter (2003). *Sources of sediment and nutrient to the Great Barrier Reef World Heritage Area*. ACTFR Report number 03/11. Australian Centre for Tropical Freshwater Research, Townsville.
- Chiew, F. and P. Scanlon (2002). *Estimation of pollutant concentrations for EMSS modelling of the south-eastern Queensland region*. CRCCH Technical Report number 02/02. Cooperative Research Centre for Catchment Hydrology, Melbourne.
- Cotton, F.A. and G. Wilkinson (1962). *Advanced Inorganic Chemistry: A Comprehensive Text*. Interscience, New York.
- Fenchel, T., G.M. King and T.H. Blackburn (1998). *Bacterial Biogeochemistry: The Ecophysiology of Mineral Cycling*, 2<sup>nd</sup> ed. Academic Press, San Diego.
- Fitzpatrick, E.A. and H.A. Nix (1969). A model for simulating soil-water regime in alternating fallow-crop systems. *Agricultural Meteorology* 6: 303-319.
- Ford, P.W., B. Robson, P. Tillman and I.T. Webster (2005). Organic carbon deliveries and their flow related dynamics in the Fitzroy estuary. *Marine Pollution Bulletin* 51: 119-127.
- Furnas, M. (2003). *Catchments and corals: terrestrial runoff to the Great Barrier Reef*. Australian Institute of Marine Science and CRC Reef, Townsville, 334 pp.
- Haynes, D., J. Müller and S. Carter (2000a). Pesticide and herbicide residues in sediments and seagrasses from the Great Barrier Reef world heritage area and Queensland coast. *Marine Pollution Bulletin* 41: 279-287.
- Haynes, D., P. Ralph, J. Prange and B. Dennison (2000b). The impact of the herbicide diuron on photosynthesis in three species of tropical seagrasses. *Marine Pollution Bulletin* 41: 288-293.
- Jones, R., J. Muller, D. Haynes and U. Schreiber (2003). The effects of the herbicides diuron and atrazine on corals of the Great Barrier Reef (Australia). *Marine Ecology Progress Series* 251: 153-167.

- Kalantzi, O.I., R.E. Alcock, P.A. Johnston, D. Santillo, R.L. Stringer, G.O. Thomas and K.C. Jones (2001). The Global Distribution of PCBs and Organochlorine Pesticides in Butter. *Journal of Environmental Science and Technology* 35: 1013-1018.
- Margvelashvili, N., B. Robson, P. Sakov, I.T. Webster, J. Parslow, M. Herzfeld and J. Andrewartha (2003). *Numerical modelling of hydrodynamics, sediment transport and biogeochemistry in the Fitzroy estuary*. Coastal CRC Technical Report No. 10. CRC for Coastal Zone, Estuary and Waterway Management; Indooroopilly. 53 pp.
- Milliman, J.D., C.P. Summerhayes and H.T. Barreto (1975). Oceanography and suspended matter off the Amazon River, February-March 1973. *Journal of Sedimentary Petrology* 60: 456-470.
- Noble, R.M., L.J. Duivenvoorden, S.K. Rummenie, P.E. Long and L.D. Fabbro (1996). *Downstream effects of landuse in the Fitzroy catchment*. Summary report: December 1996. DNR, Brisbane.
- Packett, R., P. Ford, J. Lever, A. Britton, C. Manolis, R. Bredl and S. Watson (2004). Persistent Organic Pollutants in Eggs of the Saltwater Crocodile from Tropical Australia: a Preliminary Survey. pp 424 - 429. In: *Proceedings of the 17th Working Meeting of the Crocodile Specialist Group*, IUCN – The World Conservation Union, Gland, Switzerland and Cambridge UK.
- Payne, T.E., R. Szymczak and T.D. Waite (1998). *Phosphorus dynamics in the Fitzroy estuary*. Project report for the Great Barrier Reef Marine Park Authority, prepared by the Environment Division of ANSTO.
- Roache, P.J. (1982). *Computational Fluid Dynamics*. Hermosa, Albuquerque.
- Smith, D. (1999). Worldwide trends in DDT levels in human breast milk. *International Journal of Epidemiology* 28: 179-188.
- Webster, I.T., P.W. Ford, B. Robson, N. Margvelashvili and J. Parslow (2003). *Conceptual model of the hydrodynamics, fine sediment dynamics, biogeochemistry and primary production in the Fitzroy estuary*. Coastal CRC Technical Report No. 8. CRC for Coastal Zone, Estuary and Waterway Management; Indooroopilly. 43 pp.
- Wu, T.H., T.R. Rainwater, S.G. Platt, S.T. McMurry and T.A. Anderson (2000). Organochlorine contaminants in Morelet's crocodile (*Crocodylus moreletti*) eggs from Belize. *Chemosphere* 40: 671-678.

## APPENDIX A. PUBLICATIONS ARISING FROM PROJECT FH1

- Douglas, G., P.W. Ford, M. Palmer, R. Noble and R. Packett (2005). *Identification of sediment sources in the Fitzroy River basin and estuary, Queensland, Australia*. CRC Coastal Zone Technical Report Number 13, Indooroopilly, Queensland.
- Douglas, G., P.W. Ford, M. Palmer, R. Noble and R. Packett (2005). Fitzroy River Basin, Queensland, Australia: (I) Identification of Sediment Sources in Impoundments and Flood Events. *Marine and Freshwater Research* (In prep.).
- Douglas, G., P.W. Ford, M. Palmer, R. Noble and R. Packett (2005). Fitzroy River Basin, Queensland Australia: (II) - Identification of Estuary Bottom Sediment Sources. *Marine and Freshwater Research* (In prep.).
- Ford, P.W., B. Robson, P. Tillman and I.T. Webster (2005). Organic carbon deliveries and their flow related dynamics in the Fitzroy estuary. *Marine Pollution Bulletin* 51: 119-127.
- Packett, R., P.W. Ford, J. Lever, A. Britton, C. Manolis, R. Bredl and S. Watson (2004). Persistent organic pollutants in eggs of the Saltwater Crocodile from tropical Australia: a preliminary survey. pp 424 - 429. In: *Proceedings of the 17th Working Meeting of the Crocodile Specialist Group*, IUCN - The World Conservation Union, Gland, Switzerland and Cambridge UK.
- Webster, I.T., P.W. Ford and P. Tillman (2005). Estimating Nutrient Budgets in Tropical Estuaries Subject to Episodic Flows. *Marine Pollution Bulletin* 51: 165-173.

## APPENDIX B. ABBREVIATIONS USED IN MAIN REPORT

ADCP Acoustic Doppler Current Profiler

BB Bowen Basin

DOC Dissolved Organic Carbon

DIC Dissolved Inorganic Carbon

DOC Dissolved Organic Carbon

DIN Dissolved Inorganic Nitrogen

DON Dissolved Organic Nitrogen

DSi Dissolved Silica

FRP Filterable Reactive Phosphorus

mpb microphytobenthos

N Nitrogen

NEFB New England Fold Belt

P Phosphorus

POC Particulate organic carbon

PP Particulate Phosphorus

SB Surat Basin

TB Tertiary Basalt

TFB Thompson Fold Belt

TN Total Nitrogen

TP Total Phosphorus

TSS Total Suspended Solids

Si Silica